

Mounting instructions

EÜK screed-covered duct system

Table of contents

EÜK screed-covered duct system

Mounting instructions

Table of contents

1	About these instructions	5
1.1	Target group	5
1.2	Relevance of these instructions	5
1.3	Types of warning information	5
1.4	Depiction conventions	6
1.5	Basic standards and regulations	6
1.6	Applicable documents	6
2	Intended use	6
3	Safety	6
3.1	General safety information	6
3.2	Personal protective equipment	6
4	Necessary tools	7
5	System overview	7
5.1	System components	7
5.2	Installation principle	13
5.2.1	Screed types	14
6	Preparations for mounting	14
6.1	Calculation of the duct lengths	14
6.2	Preparing for installation	16
7	Mounting the underfloor box	17
8	Mounting the underfloor duct	19
9	Mounting the connection shackle and vertical bend	22
10	Adjusting the height of the underfloor box	26
11	Mounting the height expansion	32
12	Applying the screed	38
13	Completing mounting	40
13.1	Removing the mounting lid	41
13.2	Decoupling the underfloor box	41
13.3	Creating the earthing connection	43
13.4	Mounting the mounting lid	43
14	Applying the floor covering	44
15	Mounting the service outlets/cassettes	44
16	Performing the electrical installation	45
17	Maintaining the duct system	46
18	Dismantling the duct system	46

19 Disposing of the duct system	46
20 Technical data	46
20.1 Underfloor boxes	46
20.2 Underfloor duct	46
20.3 Vertical bend	47
20.4 Connection shackle.	48
20.5 Height extension	48
20.6 Mounting lid (for UZD)	48

1 About these instructions

1.1 Target group

These instructions are intended for the following target groups:

- Trained electrical specialists charged with mounting floor sockets
- Electrical planners and engineers charged with the planning of under-floor systems

Electrical work may only be carried out by specialist personnel with electrical training.



1.2 Relevance of these instructions

- These instructions are based on the standards valid at the time of compilation (March 2023).
- All the documents supplied with the product must be stored in an easily accessible location, so as to be available when information is required.
- We will not accept any warranty claims for damage caused through non-observance of these instructions.
- Any images are intended merely as examples. Mounting results may look different.

1.3 Types of warning information



Type of risk!

Indicates a dangerous situation. If the safety instruction is not observed, then serious or fatal injuries may occur.



Type of risk!

Indicates a dangerous situation. If the safety instruction is not observed, then medium or minor injuries may occur.

ATTENTION!

Type of risk!

Indicates a damaging situation. If the safety instruction is not observed, then damage to the product or the surroundings may occur.

Note!

Indicates important information or assistance.

1.4 Depiction conventions

Explanation of the depictions used:



Incorrect design

Correct design

1.5 Basic standards and regulations

- DIN EN 50085-1: Cable trunking systems and cable ducting systems for electrical installations – Part 1: General requirements
- DIN EN 50085-2-2: Cable trunking systems and cable ducting systems for electrical installations – Part 2-2: Particular requirements for cable trunking systems and cable ducting systems intended for mounting underfloor, flushfloor or onfloor.
- DIN VDE 0100: Low-voltage electrical installations

1.6 Applicable documents

- Declarations of conformity
- VDE symbol approval

2 Intended use

The EÜK screen-covered duct system and the corresponding underfloor boxes are used for cable routing and to install electrical resources (such as sockets, data technology and multimedia connections). The duct system is made completely from metal.

The EÜK screed-covered duct system is suitable for dry- and wet-care surfaces.

3 Safety

3.1 General safety information

Observe the following general safety information:

- Contact with electrical current can lead to an electric shock.
- Electrical work may only be carried out by specialist personnel with electrical training.
- Before the screed work, seal all the openings so that no screed can ingress.

3.2 Personal protective equipment

Protective gloves





Safety shoes



Protective glasses

4 Necessary tools

The following tools are required for the mounting of the screed-covered duct system:

- OBO anchor
- OBO flattener
- Slotted screwdriver
- Allen key (size 10)
- Laser measurement device or chalk line
- Spirit level
- Side cutter
- Angle grinder
- Philips screwdriver
- Adhesive tape (width: 50 mm)

5 System overview

5.1 System components

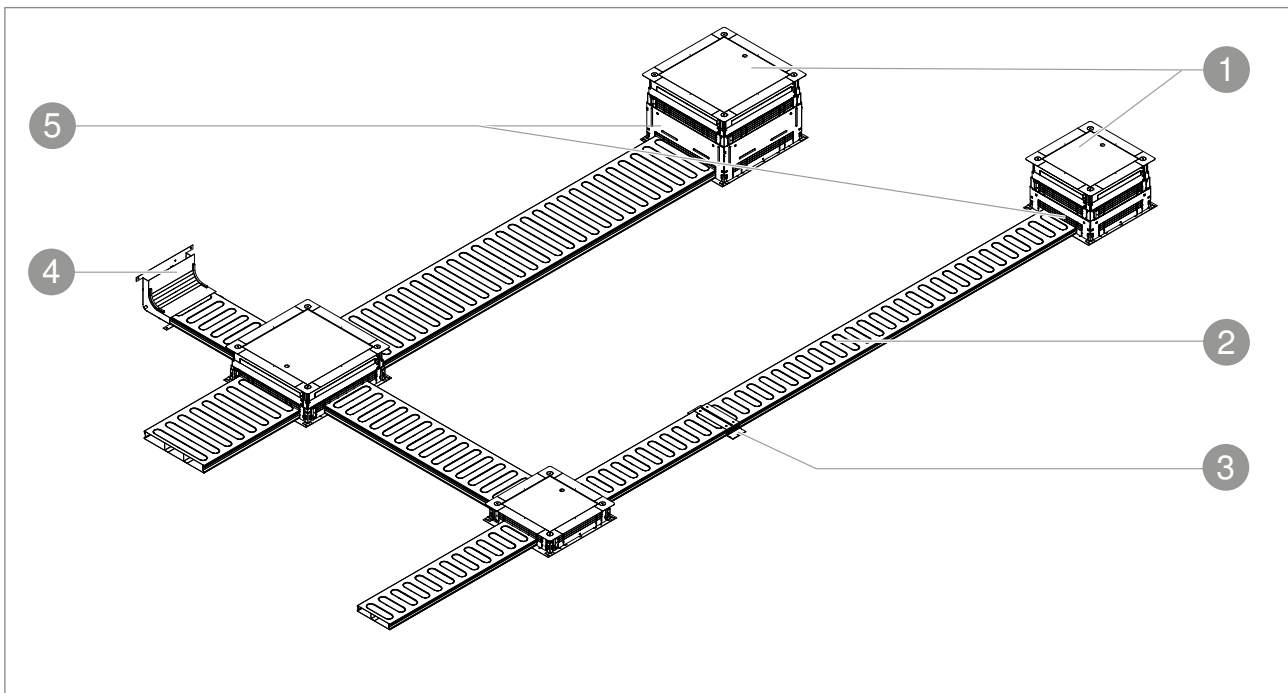
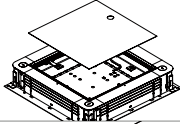
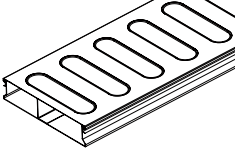
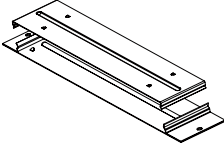
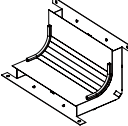
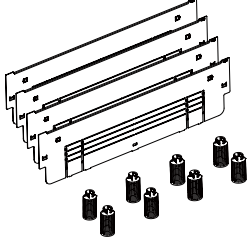

Fig. 1: System components – overall system

No.	Product name	Figure	Function
1	Underfloor box		Underfloor box with adjustable installation opening. The underfloor boxes are available in various sizes and for various floor heights.
2	Underfloor duct		2-piece underfloor duct (2- or 3-compartment) for routing cables in screed-covered underfloor systems, according to EN 50085-2-2. Removable and continuously lockable duct cover. With separating retainer in the duct base.
3	Connection shackle		2-part connection shackle for conductive mounting of screed-covered underfloor ducts. The connection shackle snaps in to the duct side walls. The electrical conductivity is ensured via the snap-in connection.
4	Vertical bend		2-part vertical bend for vertical direction changes of screed-covered underfloor ducts (wall connections, supply lines).
5	Height extension		If the floor structures differ from the standard height-adjustment heights, then the underfloor boxes can be converted to the required height with the height extension. There are two different height extensions: ASH 250 and ASH 350 for a height-adjustment range of 160–240 mm or 240–320 mm.

Tab. 1: System components – overall system

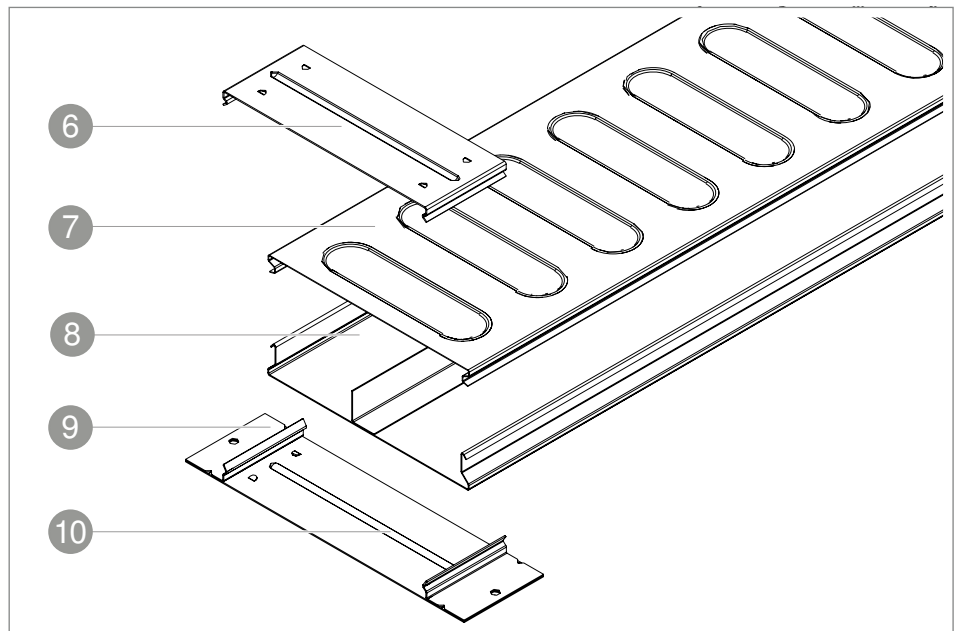

Fig. 2: System components – underfloor duct

- 6 Connection shackle cover
- 7 Duct cover
- 8 Duct base

9 Connection shackle base

10 Beading

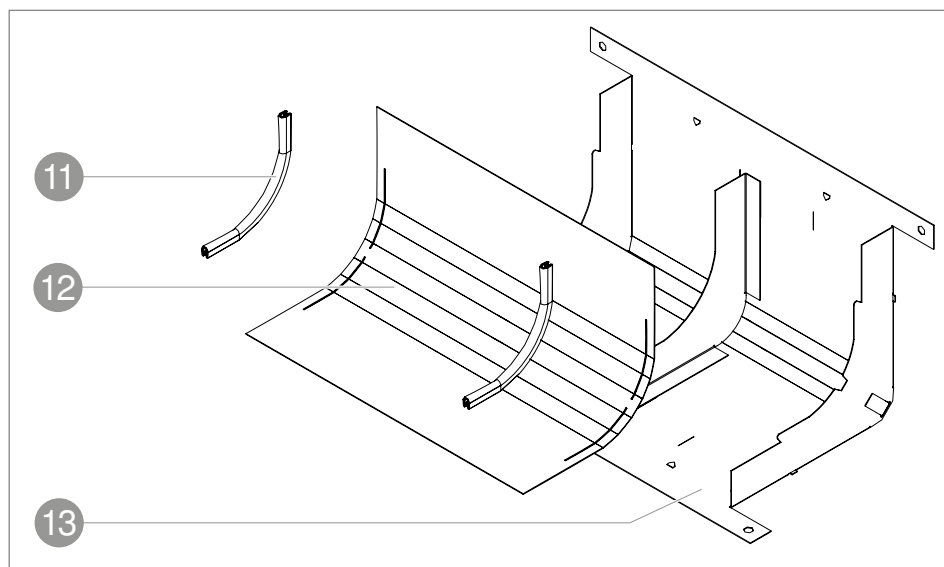

Fig. 3: System components – underfloor duct

11 Cable protection strip

12 Vertical bend cover

13 Vertical bend base

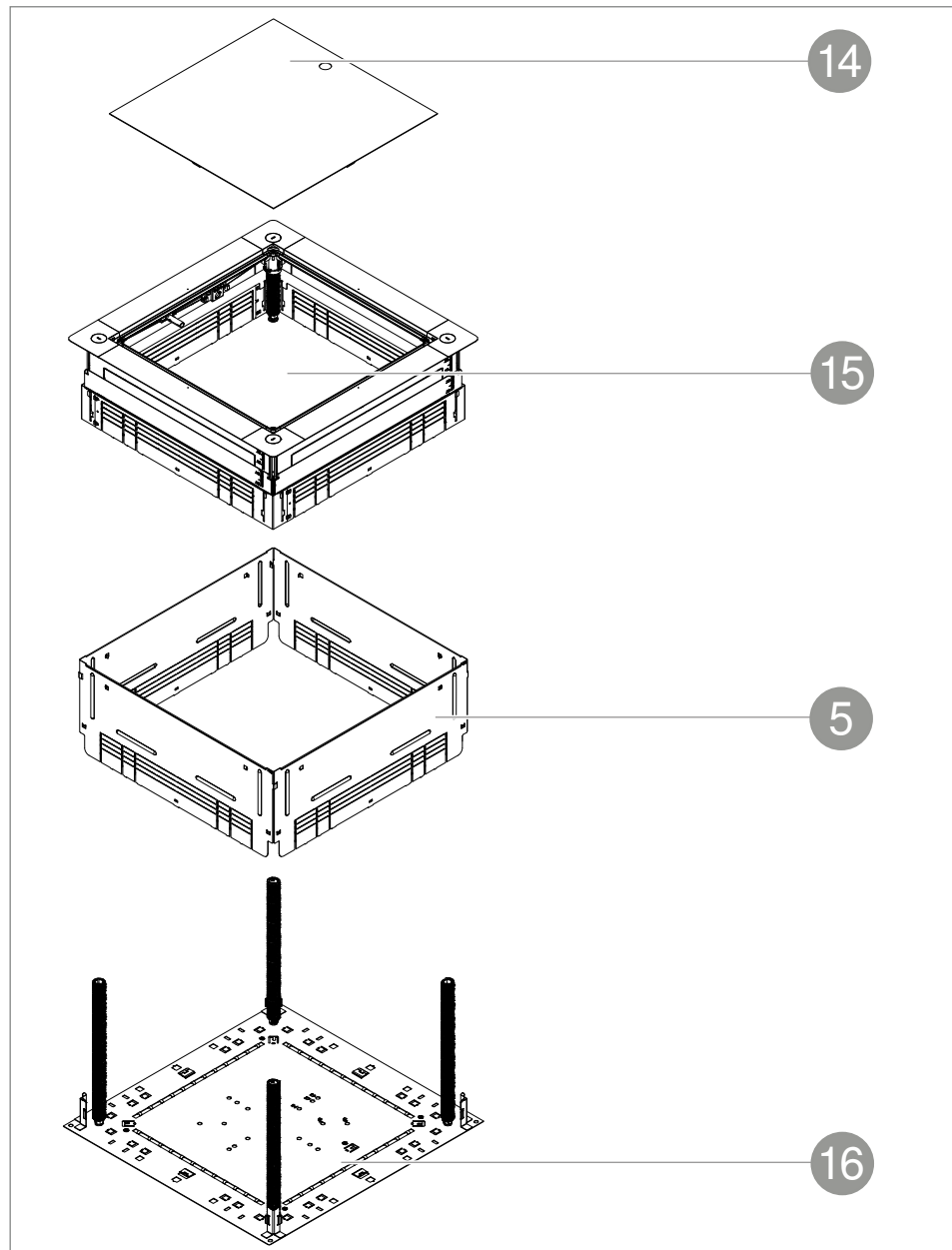

Fig. 4: System components – underfloor box

- 14 Mounting protection lid
- 15 Cover
- 5 Height extension (240/320)
- 16 Base

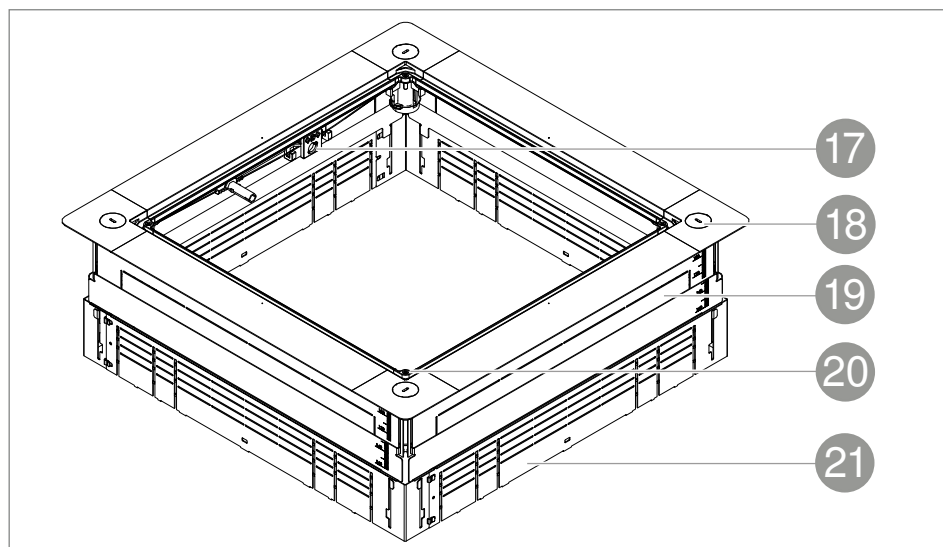

Fig. 5: System components – underfloor box cover

- 17 Rapid height-adjustment unit
- 18 Cap
- 19 Fixing panel
- 20 Countersunk screw
- 21 Side wall

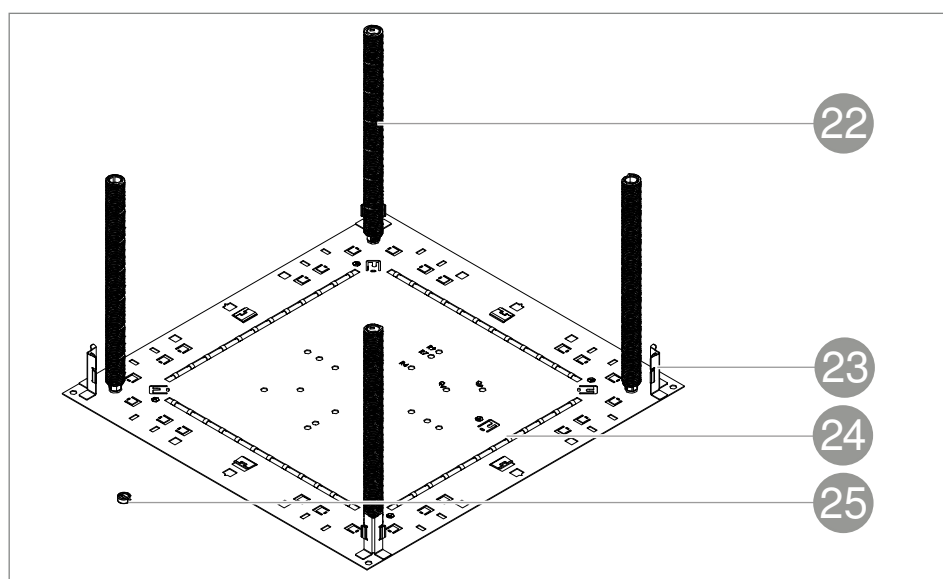

Fig. 6: System components – underfloor box base

- 22 Threaded rod
- 23 Guide angle
- 24 Floor plate
- 25 Slotted drive adapter for threaded rods

The screed-covered underfloor ducts for the EÜK system and the corresponding accessories are produced from strip-galvanised steel.

Component	Material thickness
Cover	0.6 mm
Partition	0.8 mm
Floor plate	0.8 mm
Bend	0.6 mm
Strap	1 mm

Tab. 2: Material thickness

The ducts are available in the widths 190, 250 and 350 mm and in the heights 28, 38 and 48 mm. The underfloor ducts with a duct height of 58 mm are only available in the duct widths 250 and 350 mm. The underfloor ducts are supplied, ready for mounting, with a length of 2,000 mm.

During mounting, the duct height must always be regarded in conjunction with the height of the mounted underfloor box. The underfloor box may not fall below a certain minimum height. Refer to the following table for the exact assignment:

Duct height	Min. height of the underfloor box
28 mm	80 mm
38 mm	90 mm
48 mm	100 mm
58 mm	110 mm

Tab. 3: Assignment of duct height to min. height of the underfloor box

To separate different voltage levels and stabilise the underfloor ducts, they have asymmetrically/symmetrically arranged separating retainers in the lengthwise direction. The various duct widths are equipped with a different number of separating retainers:

Duct width	Number of separating retainers
190 mm	1
250 mm	1/2
350 mm	2

Tab. 4: Assignment of duct height to min. height of the underfloor box

Various cassettes and service outlets can be mounted in the screed-covered duct system using the underfloor boxes. They can be equipped with electrical resources. Sockets, data and multimedia connections can be used with the Modul 45® series.

5.2 Installation principle

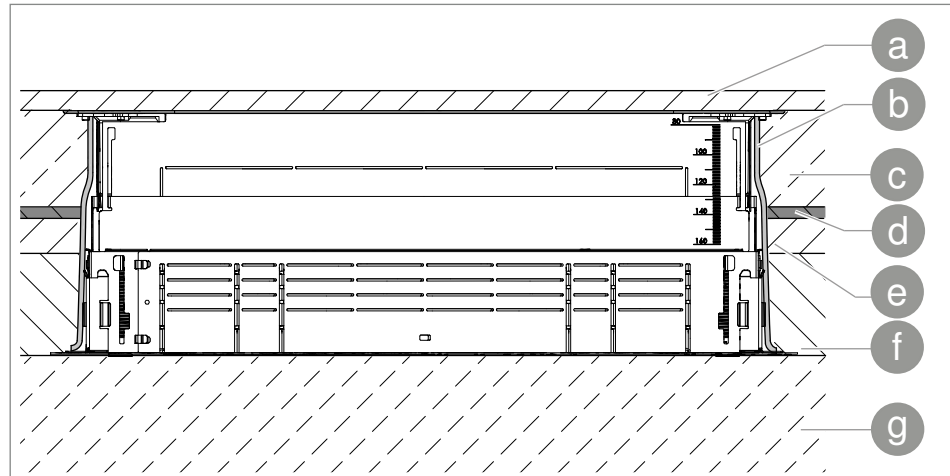

Fig. 7: Installation principle of the screed-covered duct system – underfloor box

Components in the floor cross-section (floor structure/height conditions may deviate depending on the floor planning) during the mounting of the underfloor box:

- a Floor covering
- b Separating layer
- c Floor
- d PE film
- e Footfall sound
- f Heat insulation
- g Raw concrete

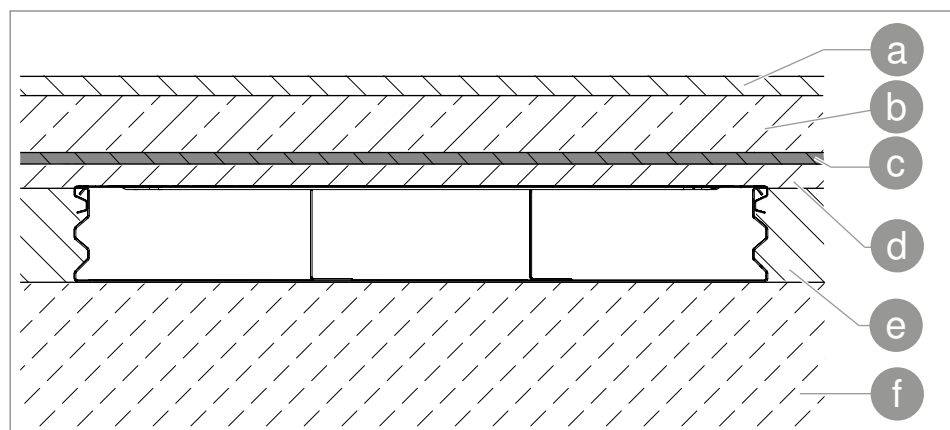

Fig. 8: Installation principle of the screed-covered duct system – duct

Components in the floor cross-section (floor structure/height conditions may deviate depending on the floor planning) during the mounting of the underfloor duct:

- a Floor covering
- b Floor
- c PE film

- d Footfall sound
- e Heat insulation
- f Raw concrete

5.2.1 Screed types

The screed-covered duct system is suitable for installation in all screed types (according to DIN 18560).

Some screed types (magnesia screed, poured asphalt) require appropriate preliminary work due to the properties of the screed materials.

ATTENTION!

Product damage!

The underfloor box contains plastic parts. For this reason, the underfloor boxes must be protected against the effects of heat (< 55 °C). When using poured screed or hot screed, use appropriate insulation.

6 Preparations for mounting

6.1 Calculation of the duct lengths

During the planning and determination of the effective cable lengths of the underfloor ducts, the following deduction dimensions should be taken into account.

Note!

The deduction dimensions are always measured from duct stop to duct stop (see detailed view in Fig. 7).

Article	Type	Deduction dimension A
Vertical bend	VK...	130 mm
Underfloor box	UGD/UZD 250	300 mm
	UGD/UZD 350	390 mm
Connection shackle	VL...	8 mm

Tab. 5: Deduction dimensions

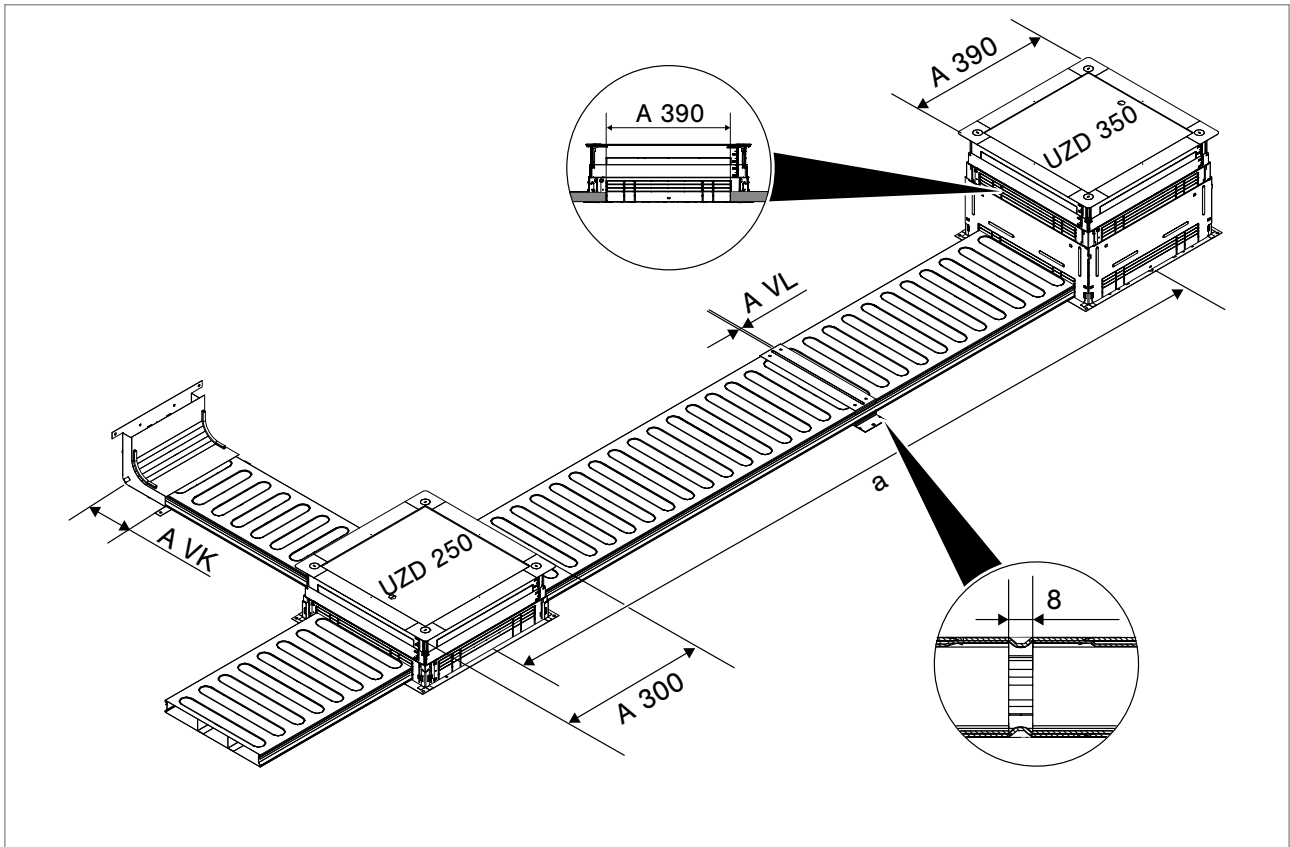

Fig. 9: Deduction dimensions

Legend

- a Distance from box centre to box centre
- A 280 Deduction dimension to UZD 250
- A 380 Deduction dimension to UZD 350
- A VL Deduction dimension, connection shackle
- A VK Deduction dimension, vertical bend

Example

- a = 2,500 mm
- A 250 = 300 mm
- A 350 = 390 mm
- A VL = 8 mm

$$\begin{aligned}
 \text{effective duct length} &= a - \frac{A\ 250}{2} - \frac{A\ 350}{2} - A\ VL \\
 \text{effective duct length} &= 2.500\ \text{mm} - \frac{300\ \text{mm}}{2} - \frac{390\ \text{mm}}{2} - 8\ \text{mm} \\
 \text{effective duct length} &= 2.147\ \text{mm}
 \end{aligned}$$

Fig. 10: Formula for calculating the deduction dimensions

6.2 Preparing for installation



Risk of electric shock!

The duct system must be connected in a manner that is fully conductive! The mounting of the screed-covered duct system takes place on the raw floor, as the required electrical connection would not otherwise be guaranteed.

ATTENTION!

Risk of damage!

Product damage to the height-adjustment units! During the construction phase, do not stand on the underfloor box, otherwise the duct system will not function. The damaged underfloor boxes must be replaced.

1. Create a clean, even raw floor as the basis for the screed-covered duct system.

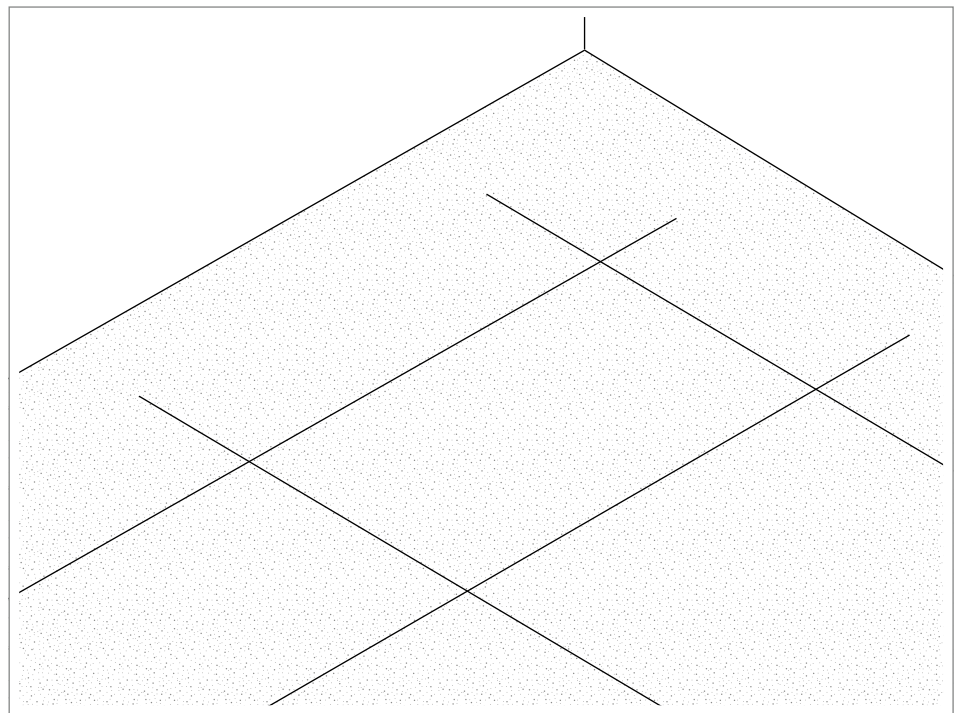

Fig. 11: Preparations for mounting

2. Mark the planned cable routes and intersection points of the underfloor box ① using a suitable tool (e.g. laser measurement device or chalk line) on the floor.

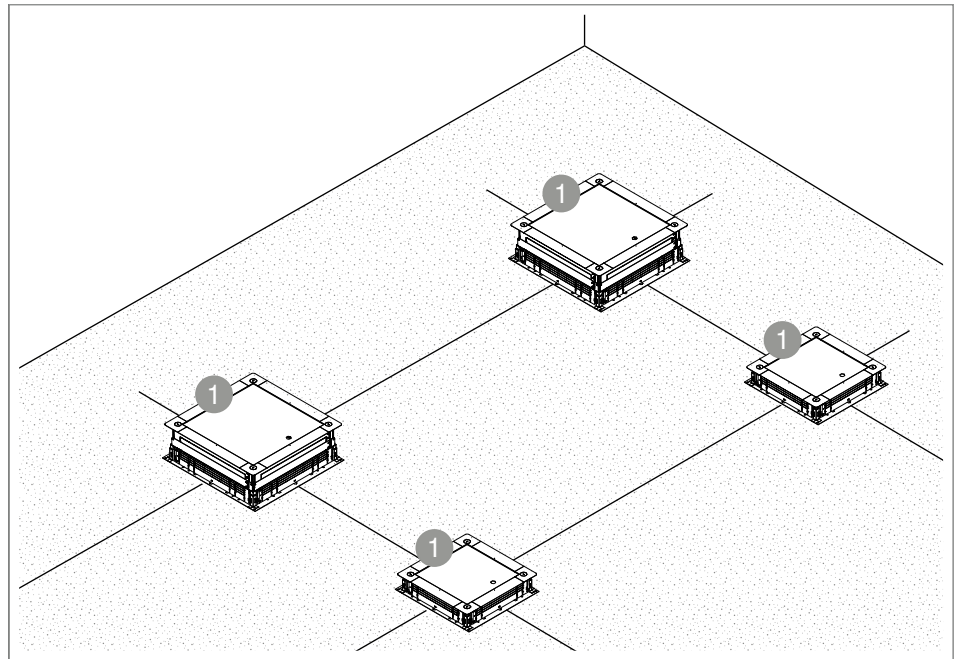

Fig. 12: Aligning the underfloor box

3. Align the underfloor box ① to the intersection points.
4. Determine the length of the required underfloor ducts ②.

7 Mounting the underfloor box

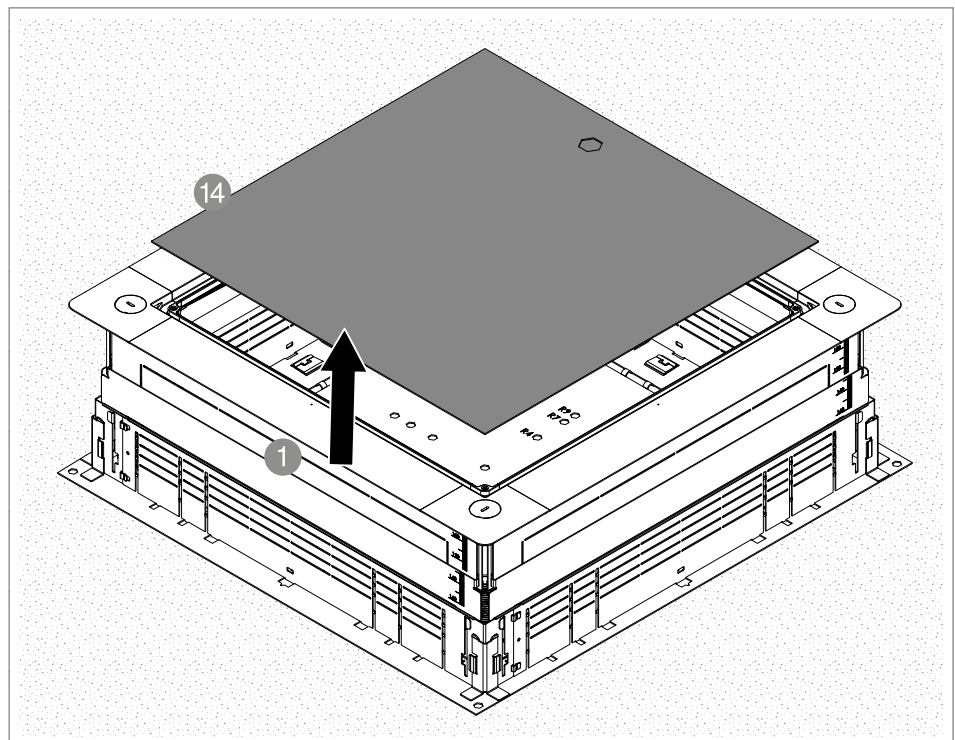

Fig. 13: Removing the mounting lid

1. Remove the mounting lid ⑭ from the underfloor box ①.

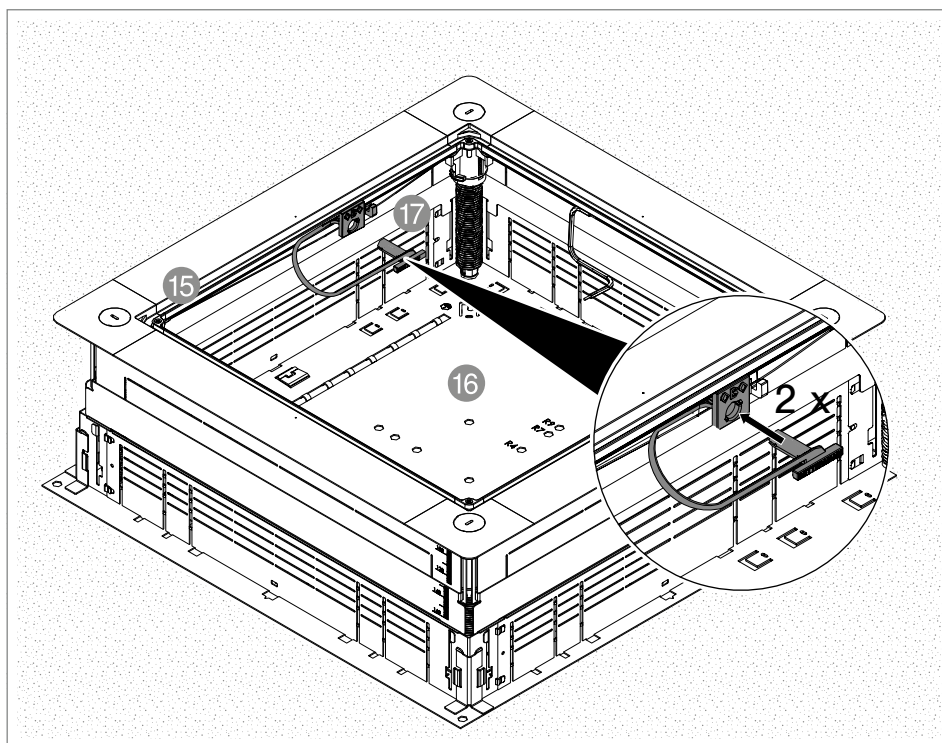

Fig. 14: Releasing the underfloor box

2. Release the connection between the cover **15** and the base **2** with the quick height adjuster **17**. To do this, push the two sides of the quick height adjuster **17** in.

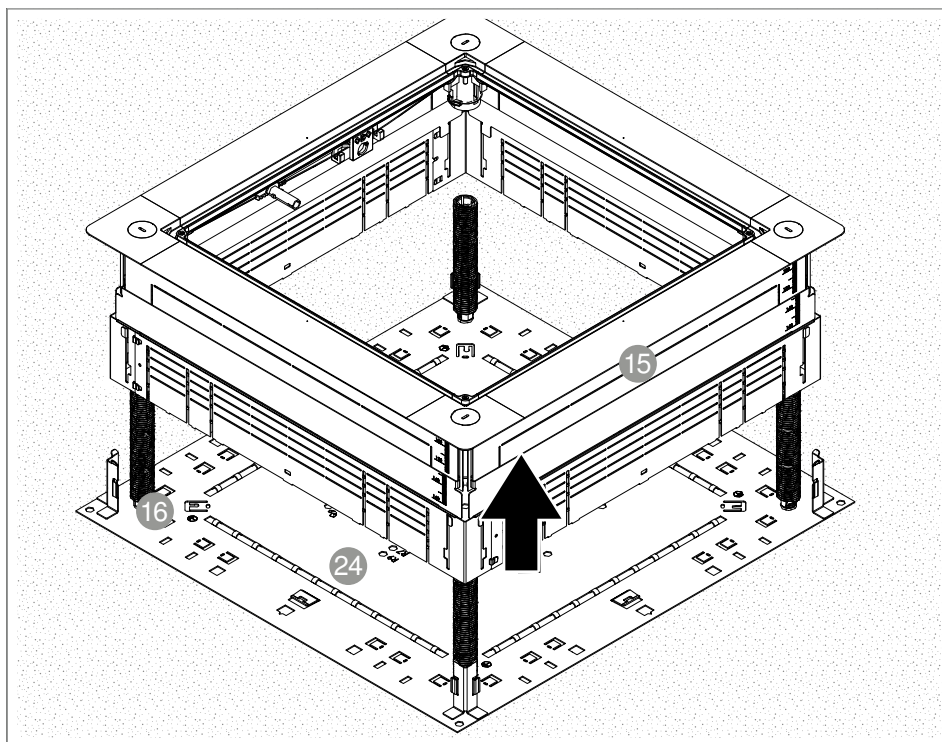

Fig. 15: Removing the underfloor box

3. Remove the cover **15** from the floor plate **24**.

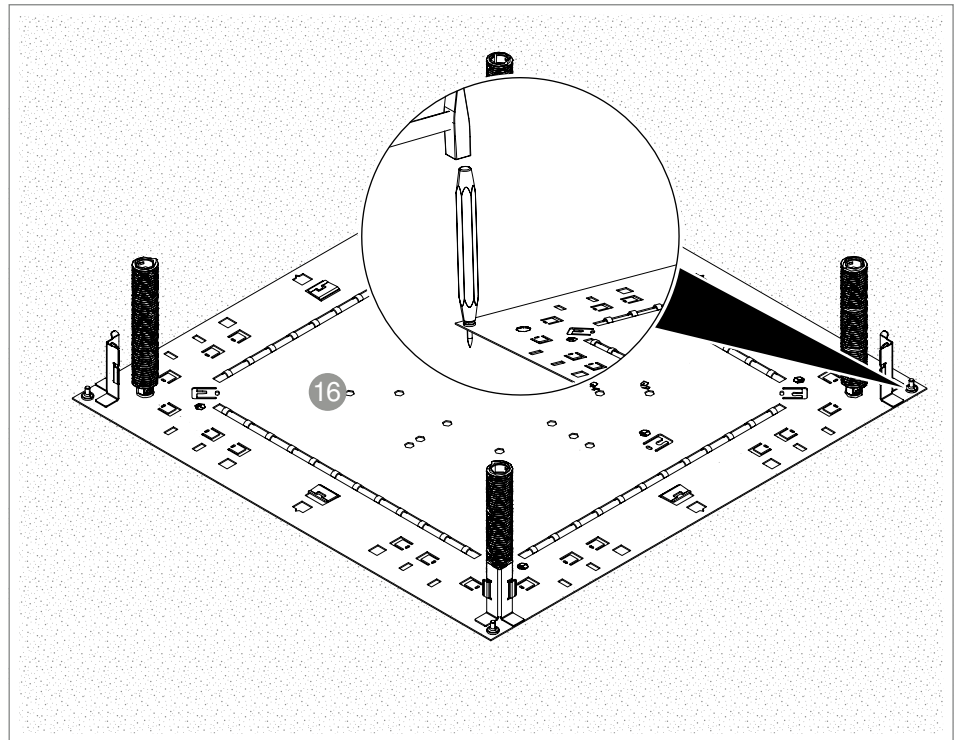

Fig. 16: Fastening the base

4. Fasten the base 16 to the 4 corners on the floor using suitable fastening material (e.g. the OBO anchor with flattener).

8 Mounting the underfloor duct

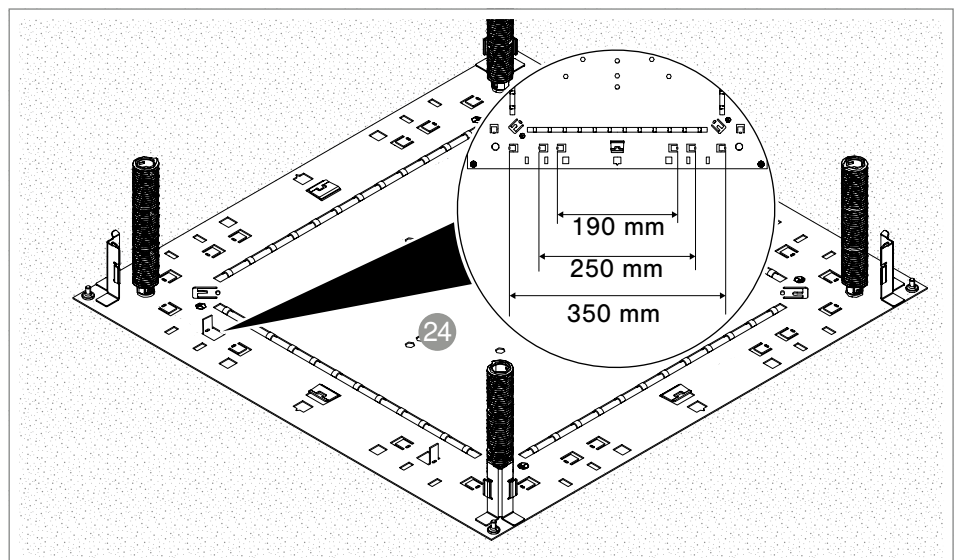

Fig. 17: Bending over the strap

1. Depending on the duct width, bend over the straps in the floor plate 24.

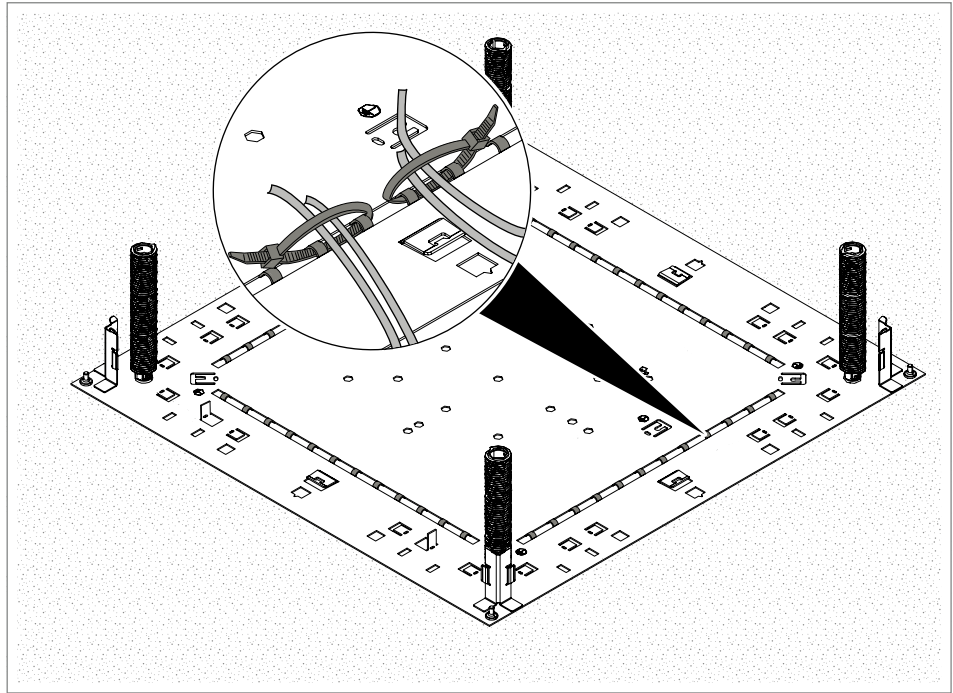

Fig. 18: Bending over the strap

Optional! *The bridges in the floor plate are intended as mounting aids to fix the cables with a cable tie.*

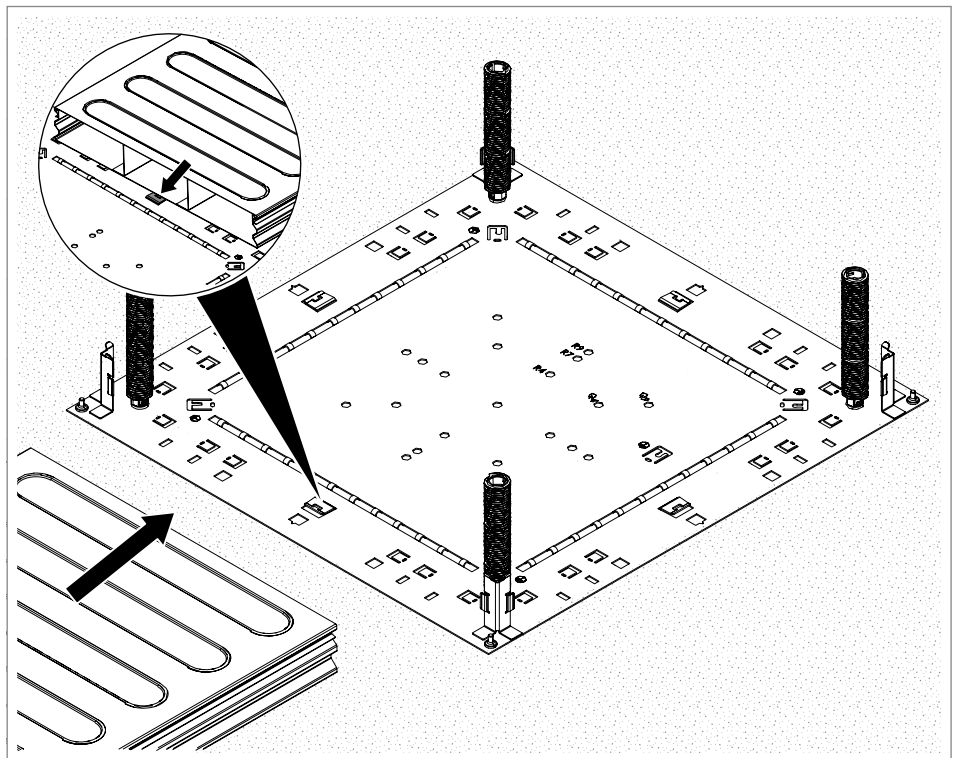

Fig. 19: Locking the duct

Note! *For reasons of stability, the cover remains on the underfloor duct.*

2. Insert the underfloor duct ② between the straps in the floor plate ②4. In doing so, push the underfloor duct between the folded-up straps.

- Push the underfloor duct ² into the centre of the floor plate ²⁴ until the underfloor duct ² visibly locks in the fastening strap.

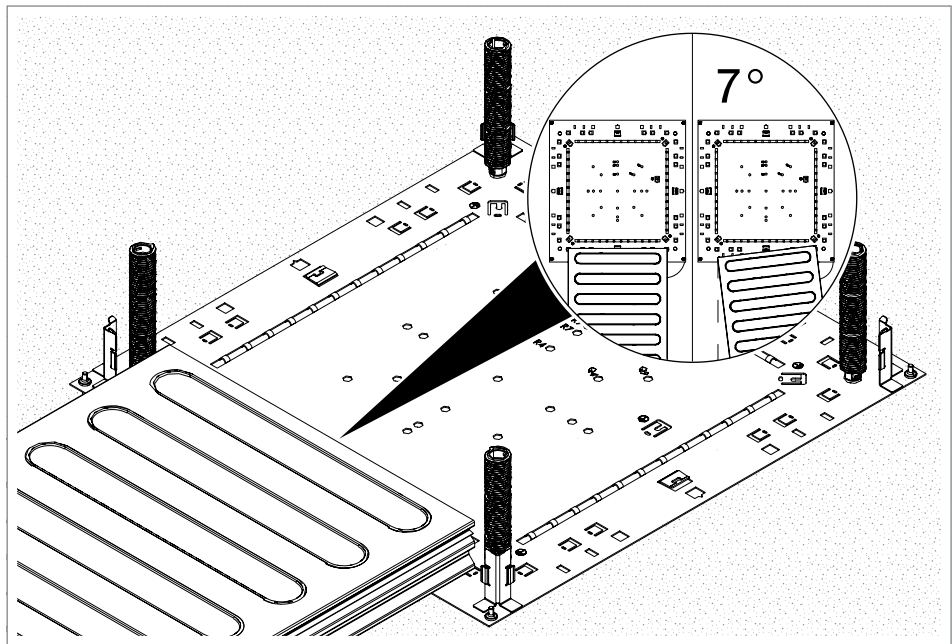

Fig. 20: Locking the duct – angle-adjustable

Note!

Directional corrections from the underfloor boxes can be made up to a deviation of 7° without any impact.

9 Mounting the connection shackle and vertical bend

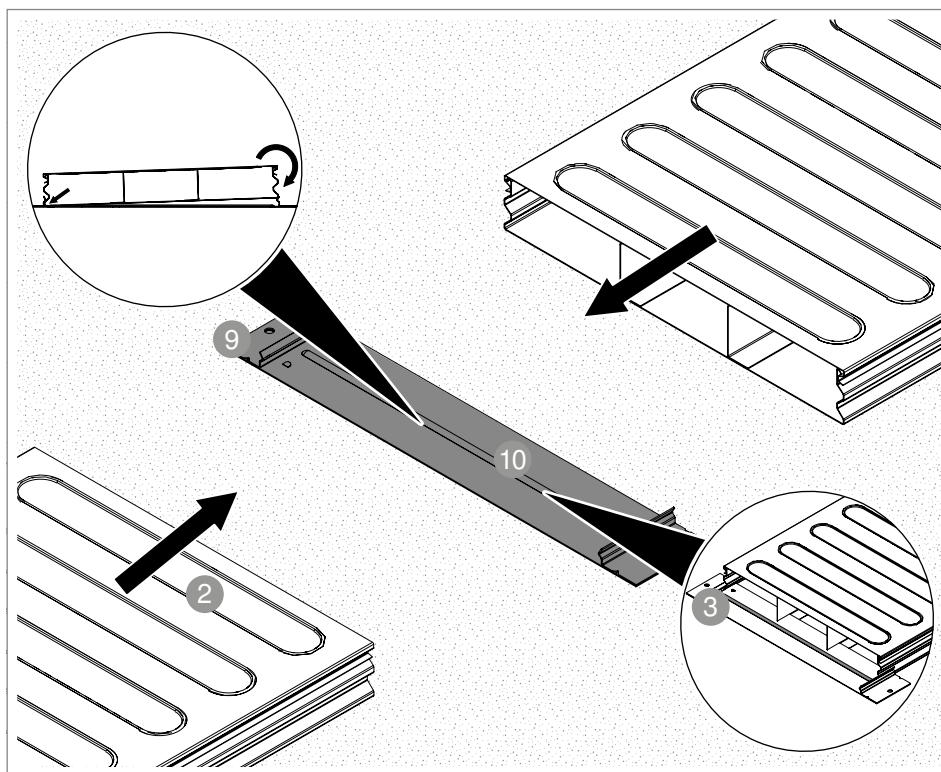

Fig. 21: Locking the duct in the connection shackle

Note!

For reasons of stability, the cover remains on the underfloor duct.

1. Insert the underfloor duct ² between the edges of the connection strap ³ next to the beading ¹⁰. In doing so, lay the underfloor duct ² on the connection shackle base ⁹ on one side and turn in the other side.

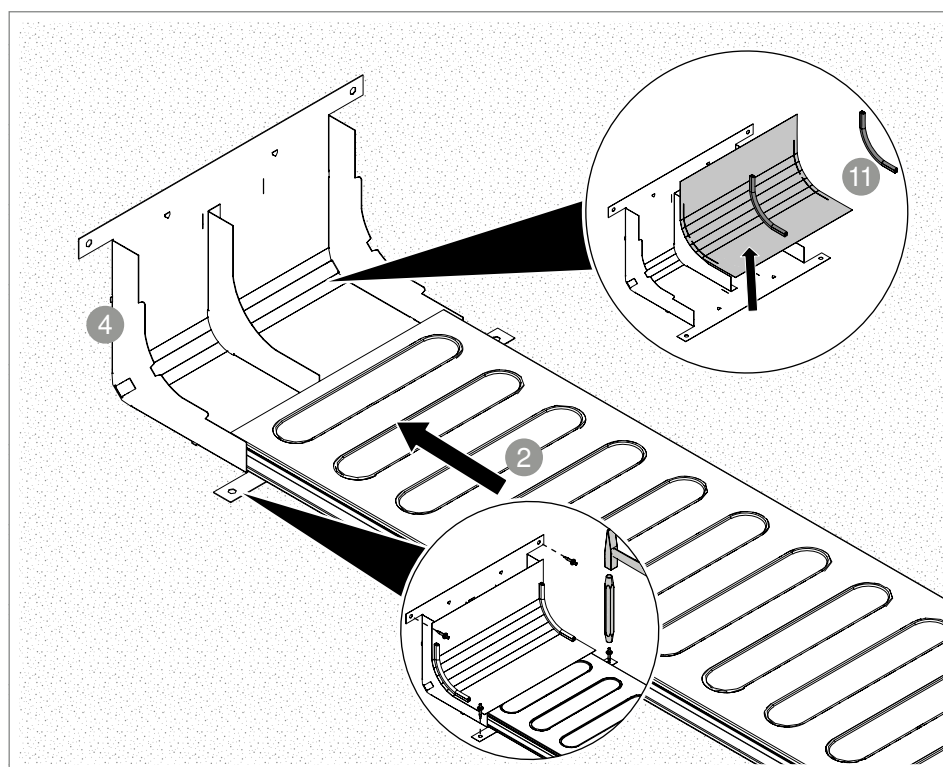

Fig. 22: Opening the vertical bend

Note!

With the two-compartment underfloor ducts, the positioning of the separating retainers must be taken into account.

2. Remove the cable protection strip 11 and the cover of the vertical bend 4.
3. Push the underfloor duct 2 into the vertical bend 4.
4. Fasten the vertical bend 4 to the four fastening points on the floor/wall using suitable fastening material (e.g. the OBO anchor with flattener).

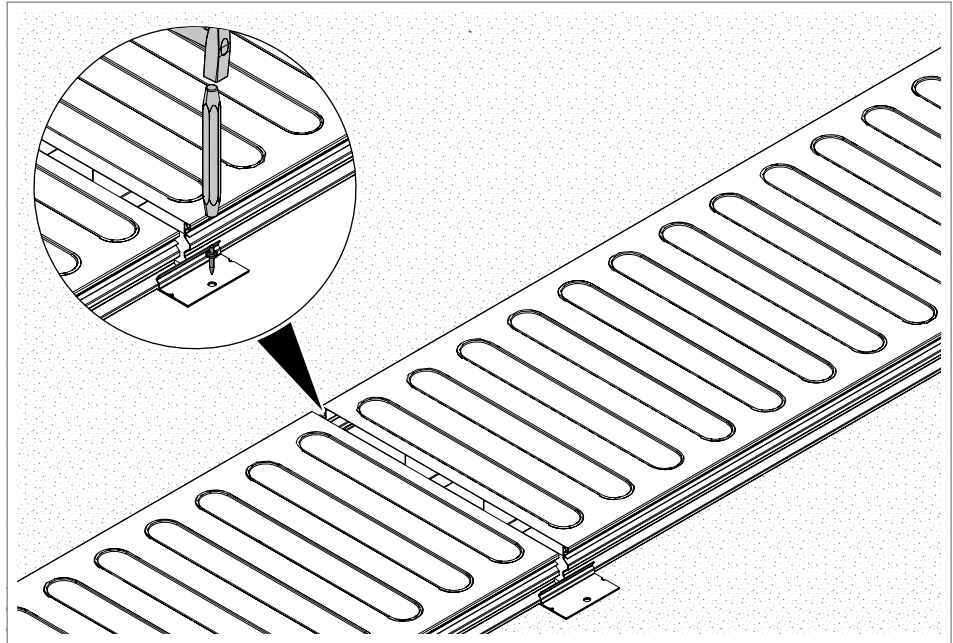

Fig. 23: Fastening the connection shackle

5. Fasten the connection shackle ③ to the floor on both sides using suitable fastening material (e.g. the OBO anchor with flattener).

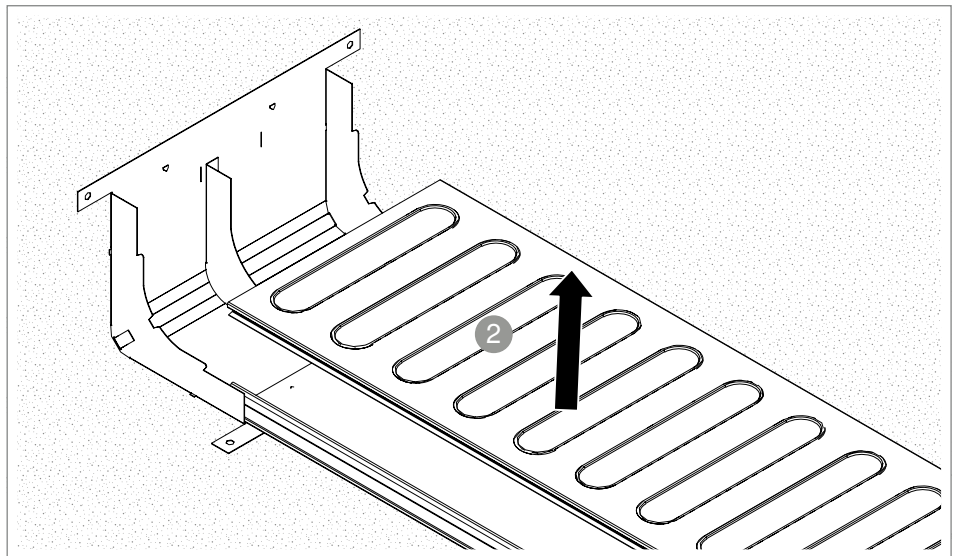

Fig. 24: Removing the covers

6. Remove the covers from the underfloor duct ② and the connection shackles ③.

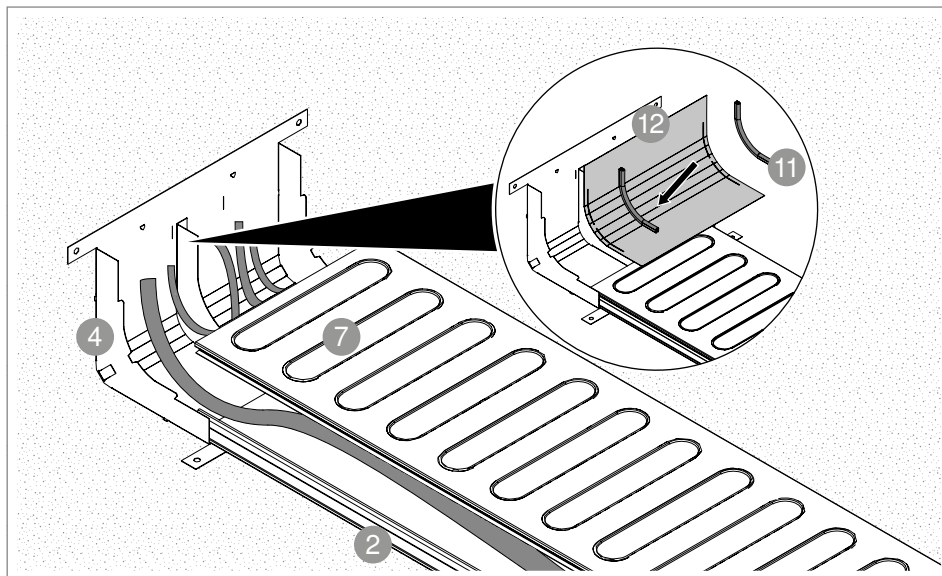

Fig. 25: Closing off the vertical bend

7. Place the cables in the underfloor duct **2** and the vertical bend **4**.
8. Close off the underfloor duct **2** with the duct cover **7**.
9. Close off the vertical bend **4** with the vertical bend cover **12** and the cable protection strip **11**.

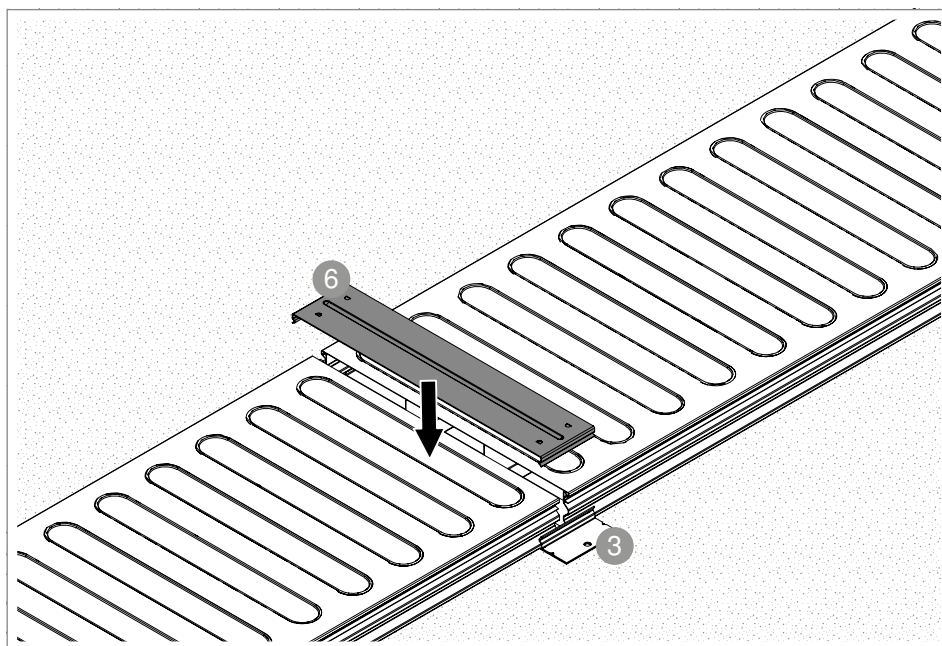

Fig. 26: Locking on the connection shackle cover

10. Close off the connection shackles **3** with the connection shackle cover **6**.

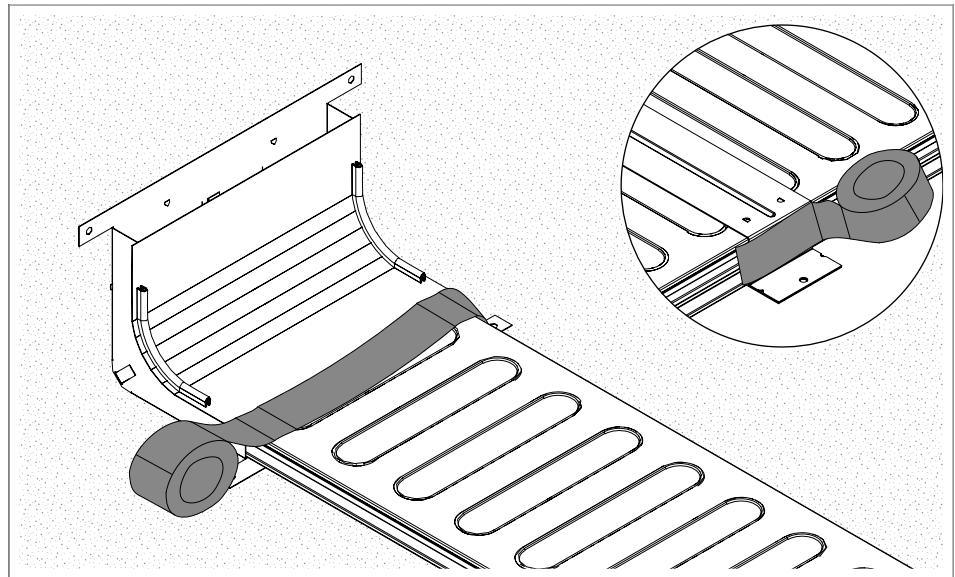

Fig. 27: Masking the component openings

11. Mask the component openings in the vertical bend **4** and the connection shackle **3** with adhesive tape, so that no screed can penetrate.

10 Adjusting the height of the underfloor box

Note!

Before starting to adjust the height of the underfloor box, the mounting height must have been fixed.

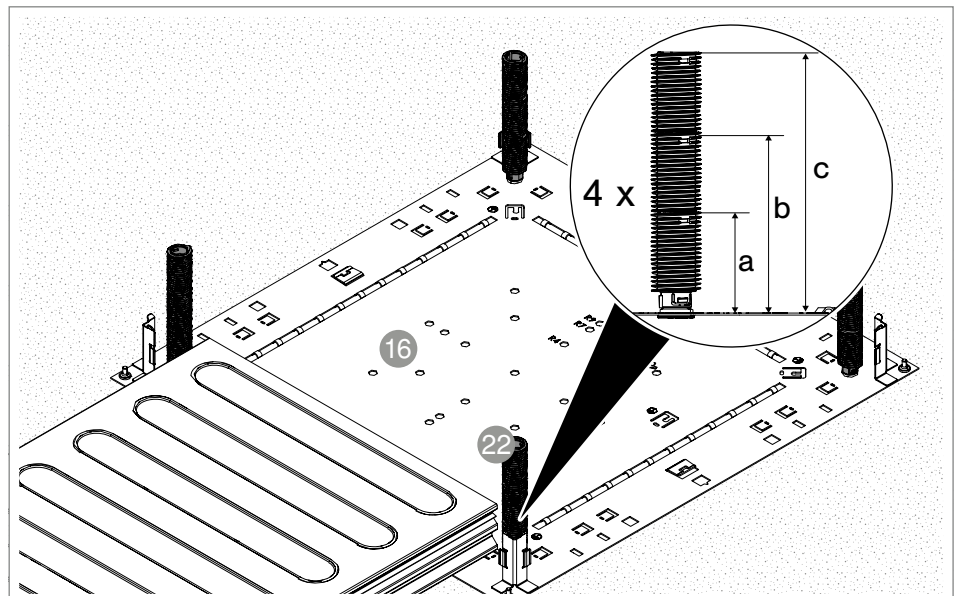

Fig. 28: Mounting threaded rods

1. Mount the threaded rods **22** in the four corners of the base **16**. The number of threaded rods **22** is dependent on the height of the screed and can be found in the following table:

Number of threaded rods	Min. height (in mm)	Max. height (in mm)
1	80	94
2	94	134
3	134	160

Tab. 6: Mounting of the threaded rods

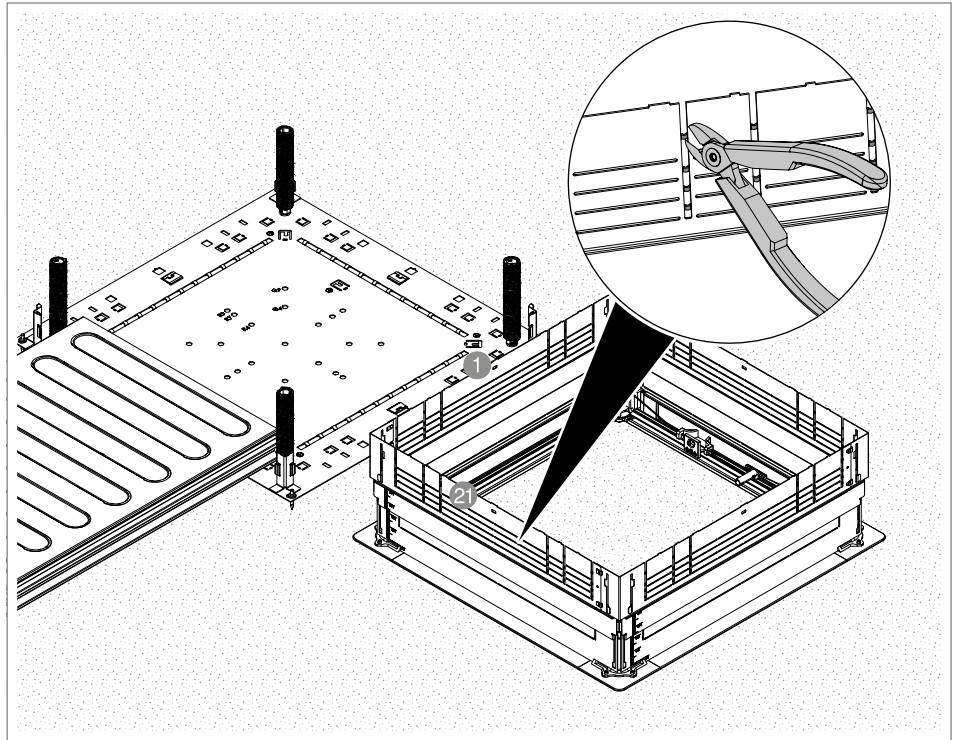

Fig. 29: Cutting the side wall

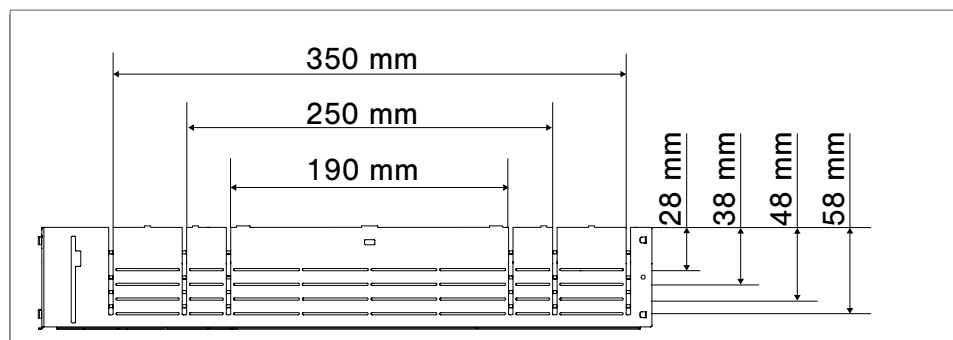

Fig. 30: Cutting the side wall – assignment of the duct height and width

2. Turn the underfloor box ① through 180°.
3. Cut the bridges of the side wall ②¹ according to the required duct height and duct width (see Fig. 30: Assignment of duct height/width).

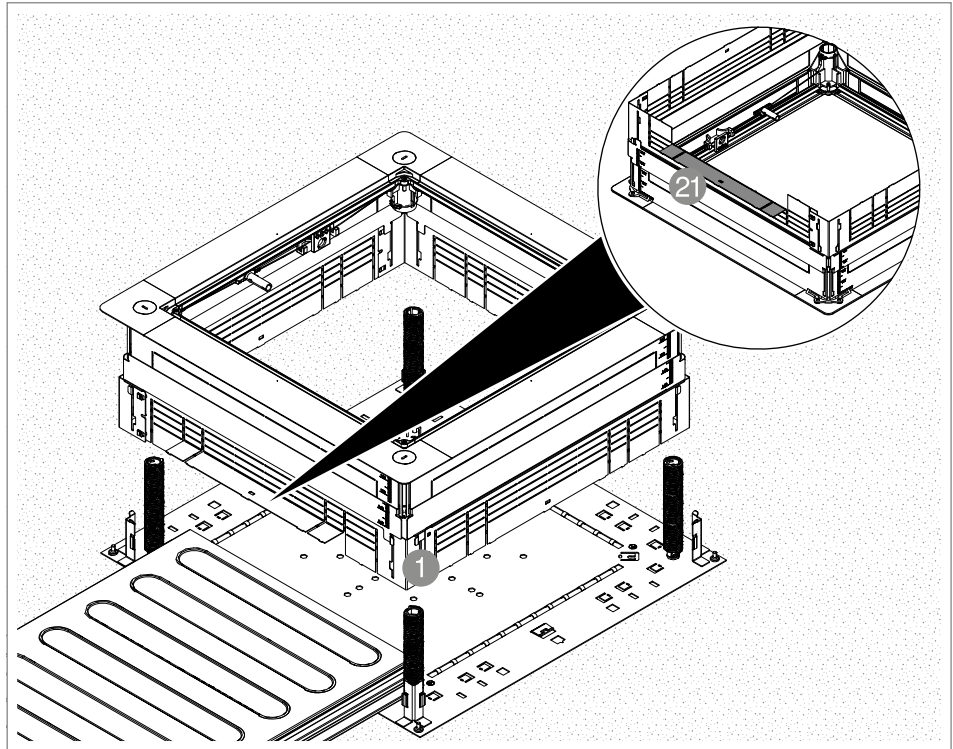

Fig. 31: Bending the side wall

4. Bend the side wall 21 (that was previously broken out) outwards.
5. Turn the underfloor box 1 through 180° again.

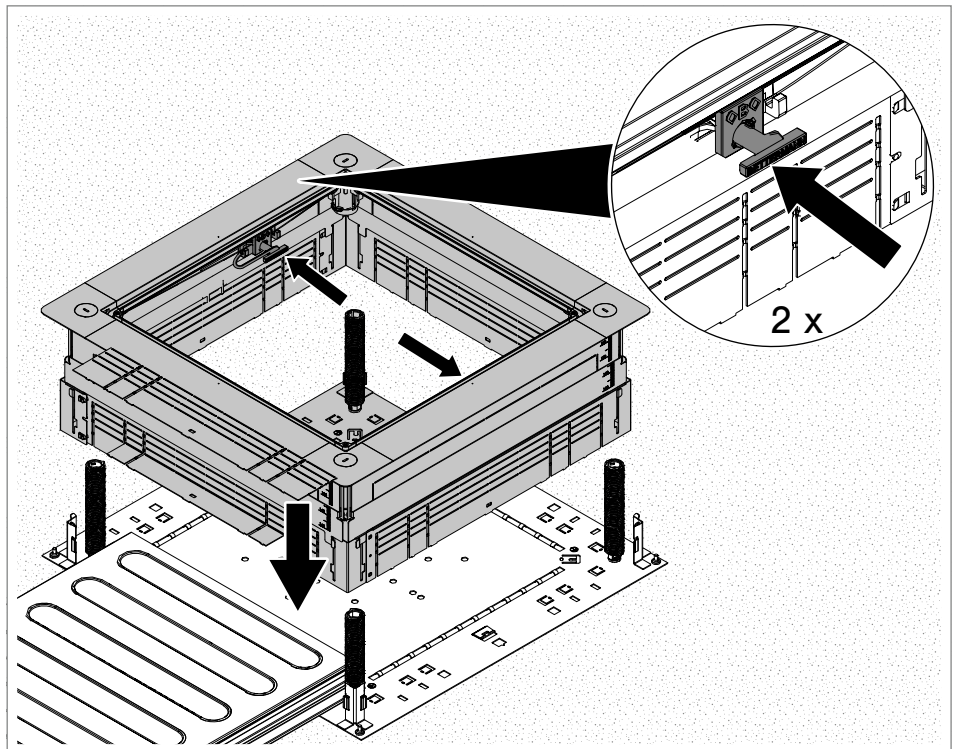

Fig. 32: Quick height adjustment

6. Place the cover 15 on the threaded rods 22.
7. Push the quick height-adjustment aid 17 in on both sides and push

the cover **15** between the guide brackets. The side walls **21** fall down onto the base plate **24**, meaning that there is no gap. When the estimated position has been reached, release the quick height-adjustment aid **17**.

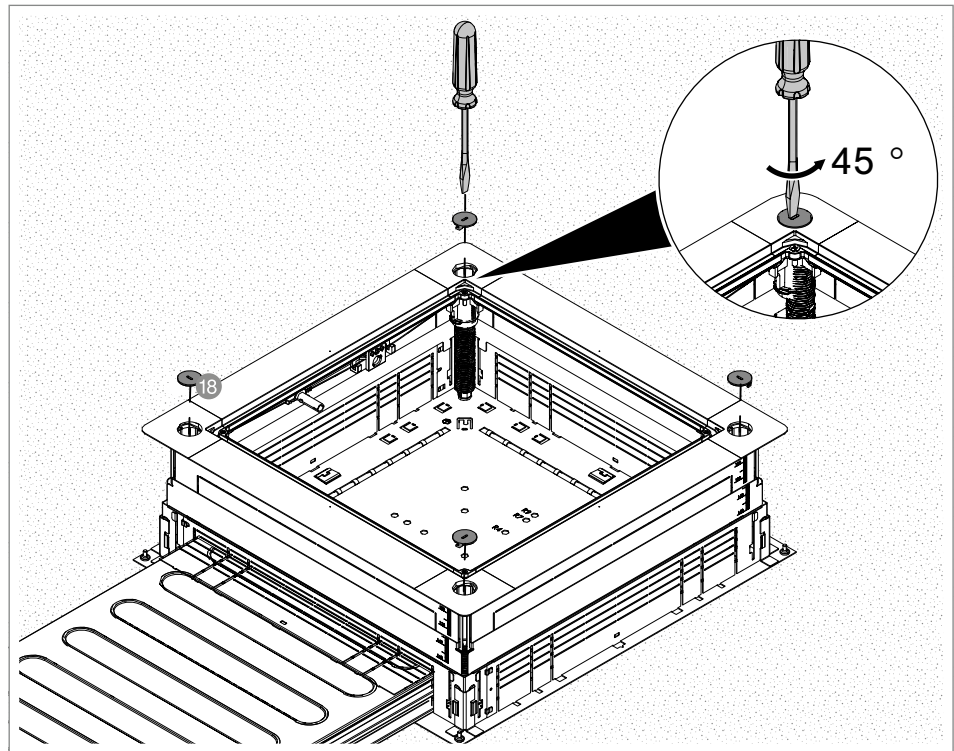

Fig. 33: Removing the cap

8. Remove the caps **18** in the four corners with a 45° turn with a slotted screwdriver.

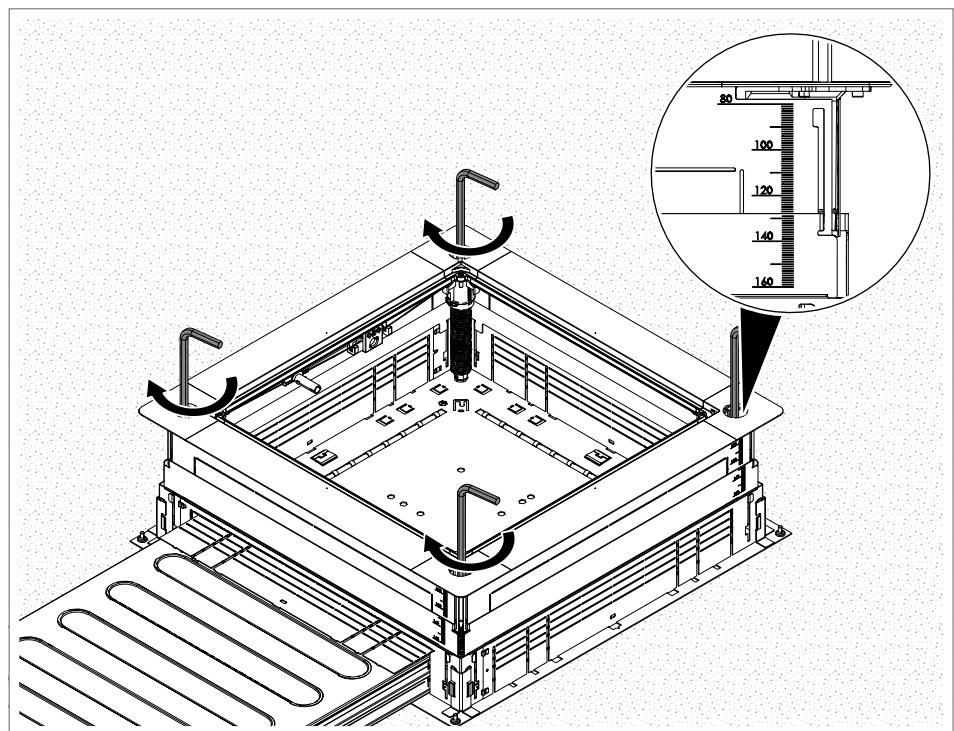

Fig. 34: Fine adjustment with an Allen key

Note! *The integrated measuring scale on the side walls of the underfloor box is suitable as an aid.*

9. Adjust the height of the underfloor box ① to the height of the upper screed edge.

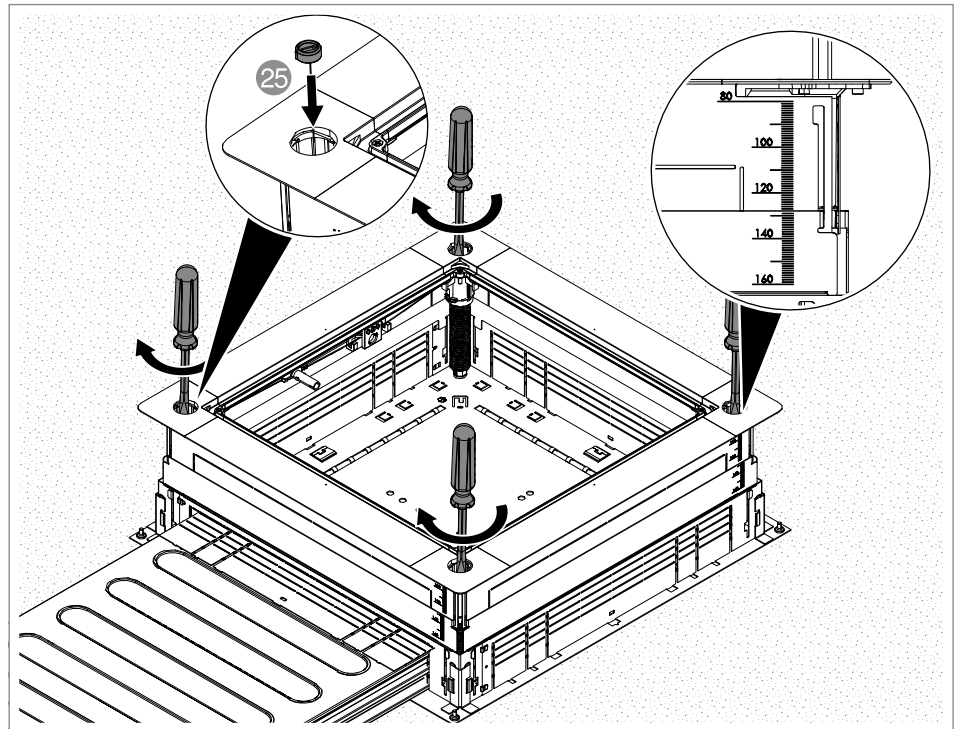

Fig. 35: Fine adjustment with a slotted drive adapter

Optional! *Fine adjustment is also possible with a slotted screwdriver.*

10. Insert the slotted drive adapter ②⑤ into the threaded rods ②②.

11. Adjust the height of the underfloor box ① to the height of the top edge of the screed

Optional! *The following action step does not have to be performed for all mounting variants.*

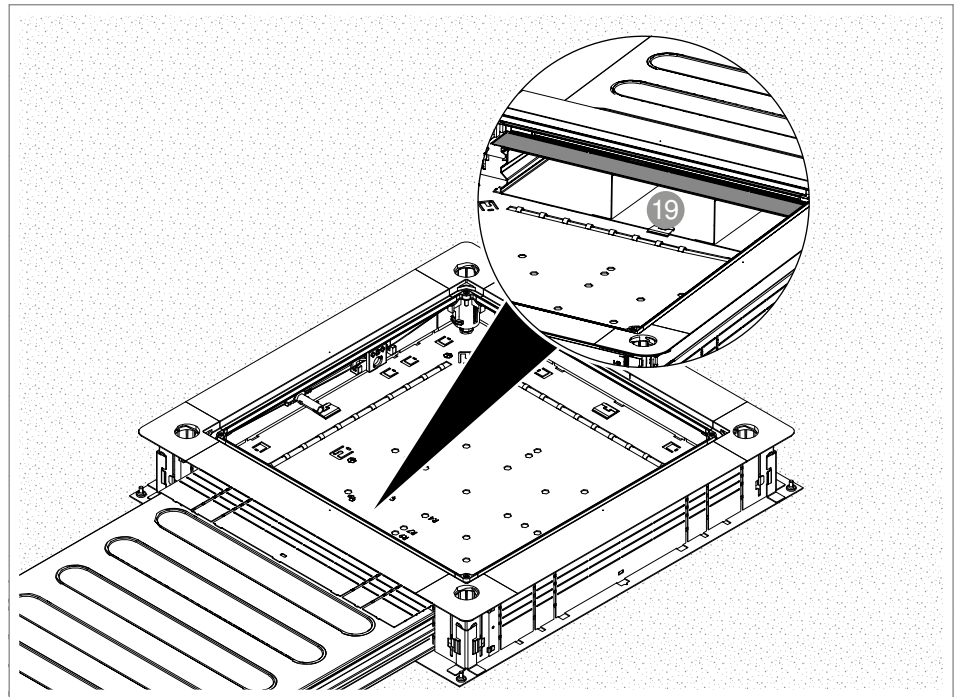

Fig. 36: Bending the fixing panel

12. Bend the outer UZD side wall outwards and bend up the inner side wall (fixing panel 19) and inwards. This action step is only required for the following mounting variants:

Duct height	Height of the underfloor box (up to)
28 mm	100 mm
38 mm	110 mm
48 mm	120 mm
58 mm	130 mm

Tab. 7: Mounting variants for which the fixing panel is bent

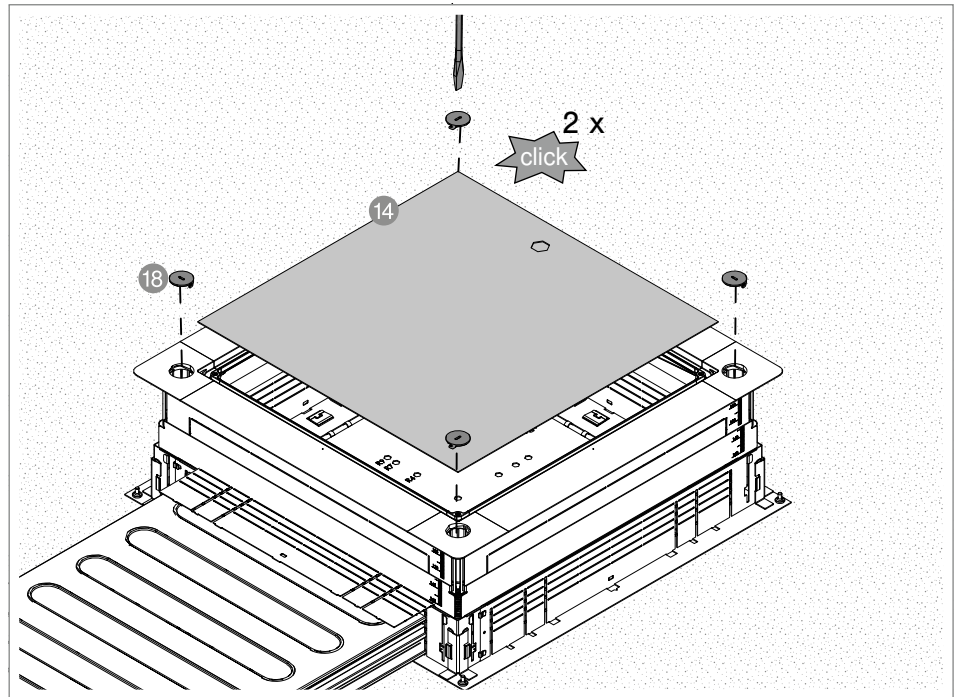

Fig. 37: Closing the underfloor box

13. Close the underfloor box **1** with the mounting protection lid **14** so that there is a click sound.
14. Close the four corners again with a slotted screwdriver and the four caps **18**. Turn in the caps **18** until there is a click sound.

11 Mounting the height expansion

Note!

In the case of structural changes (relating to the height) and tolerances after planning of the screed-covered duct system, the height difference between the underfloor box and the top edge of the screed can be compensated for using the height extension.

There are four different variants of the height extension. There are two for the UZD 250 underfloor box and two for the UZD 350 underfloor box. With the height extensions for the UZD 250 / UZD 350 underfloor box, it is possible to make height adjustments from 160 to 240 mm and from 240 to 320 mm.

All of the height adjustments consist of four individual plates, which can each be mounted like a side wall of the underfloor box.

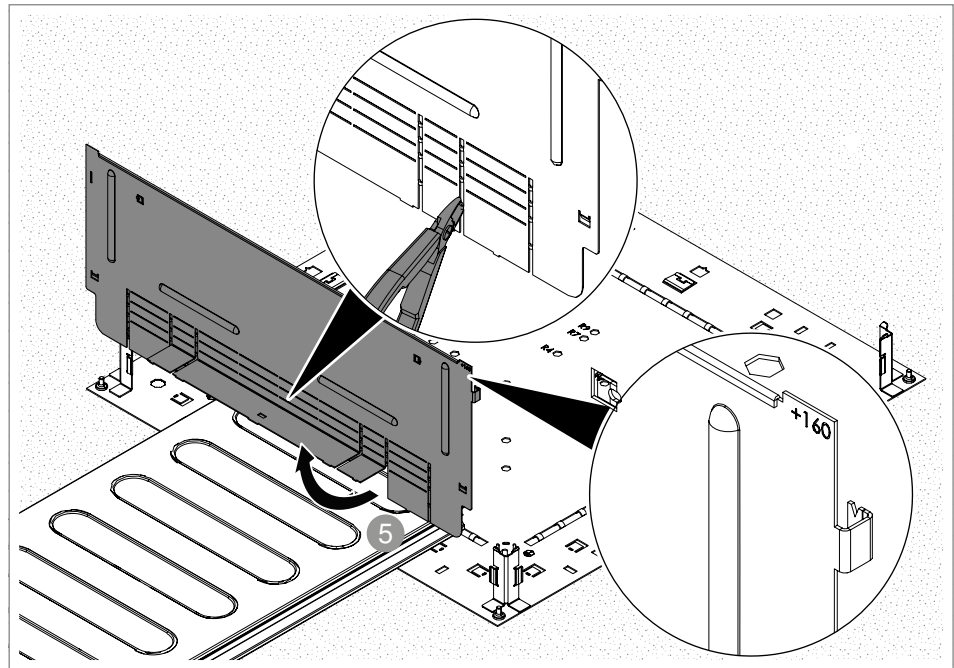

Fig. 38: Cutting the height extension

Note!

For orientation, the size of the height extension can be seen in the top right. This aid must always be legible from the outside.

1. Cut the bridges of the side wall of the height extension 5 according to the required duct height and width and bend the panel outward.

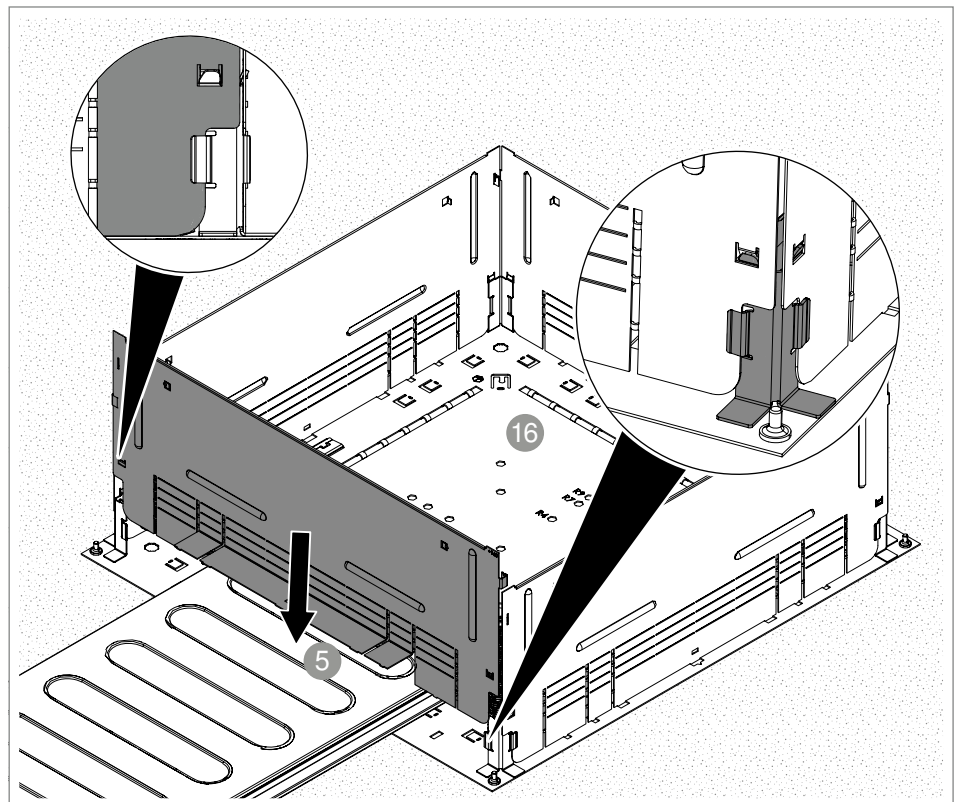

Fig. 39: Mounting the height expansion

2. Place the height extension 5 on the base 16. In doing so, ensure

that the guide bracket remains outside and the strap locks (as shown in the figure).

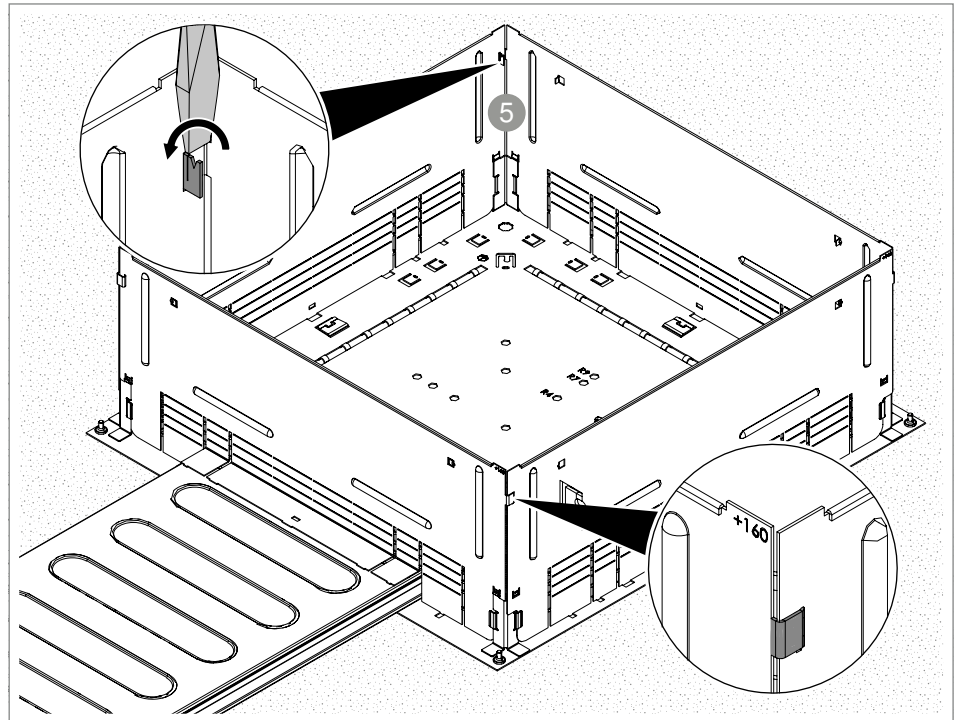

Fig. 40: Locking the side strap

Optional! *This action step is only necessary for heights of 320 mm or higher.*

3. Engage the side strap of the height extension ⑤ in the side wall of the height extension ⑤ alongside.
4. Disengage the strap with a screwdriver.

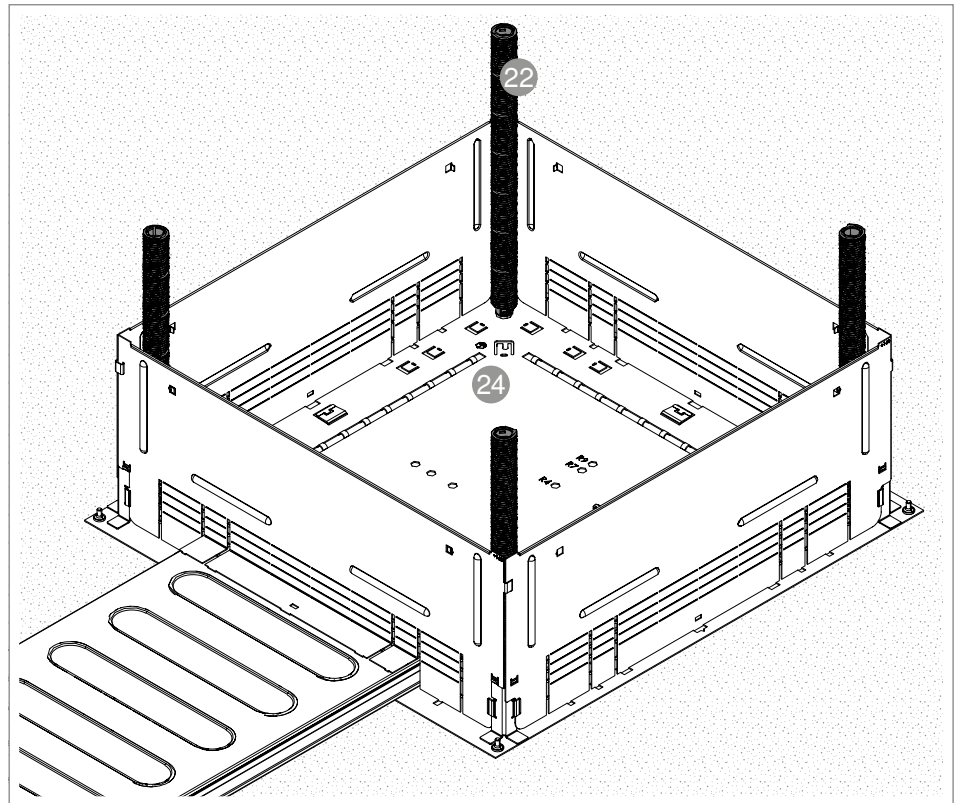

Fig. 41: Mounting threaded rods

- Mount threaded rods 22 in the four corners of the floor plate 24. The number of threaded rods 24 is dependent on the height of the screed and can be found in the following figure and table:

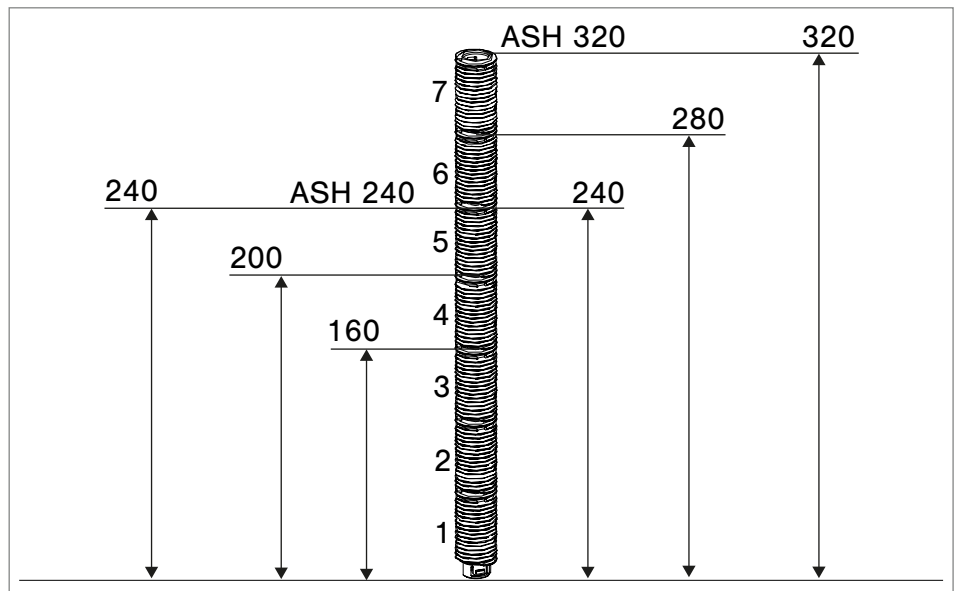

Fig. 42: Overview, number of threaded rods

Number of threaded rods	Height extension (type)	Max. height (in mm)
3	ASH 240	160
4	ASH 240	200

Number of threaded rods	Height extension (type)	Max. height (in mm)
5	ASH 240	240
5	ASH 320	240
6	ASH 320	280
7	ASH 320	320

Tab. 8: Mounting of the threaded rods

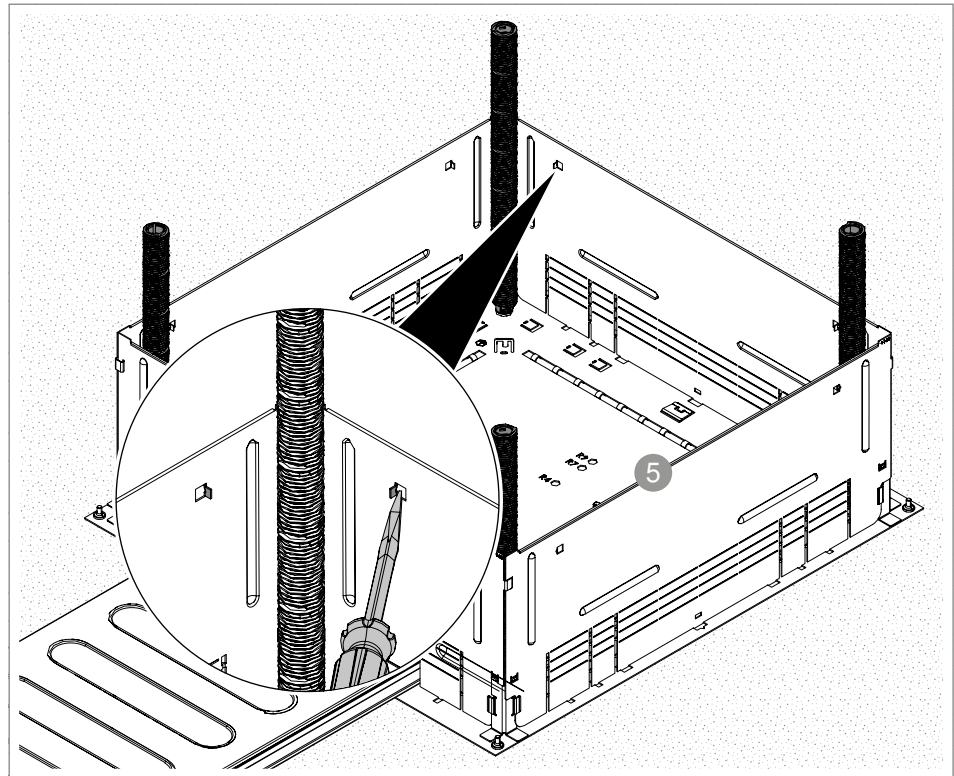

Fig. 43: Bending over the strap

- Using a suitable tool (e.g. a small slotted screwdriver), bend the straps on all the side walls of the height extension ⑤ inward.

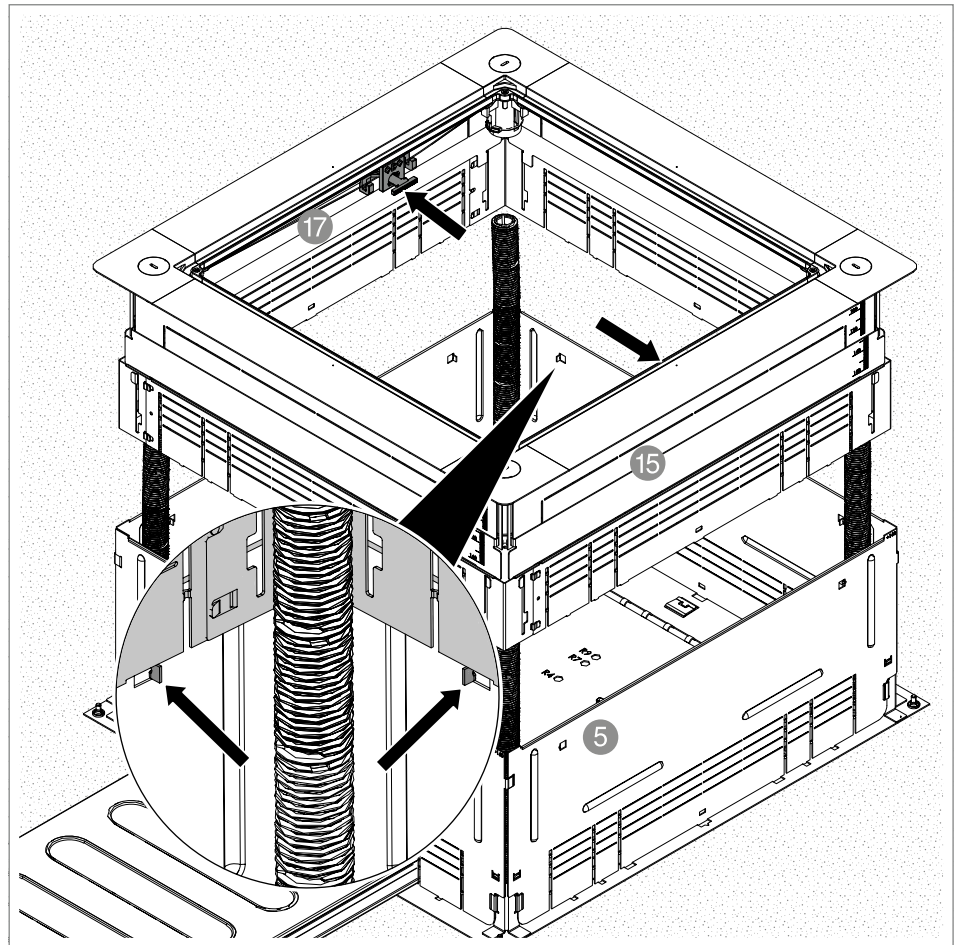

Fig. 44: Attaching the underfloor box

Note!

The cover must be located on the straps, otherwise the side wall will lose stability.

7. Attach the cover 15 to the straps on the side wall of the height extension 5. In doing so, push in the two quick height-adjustment aids 17.

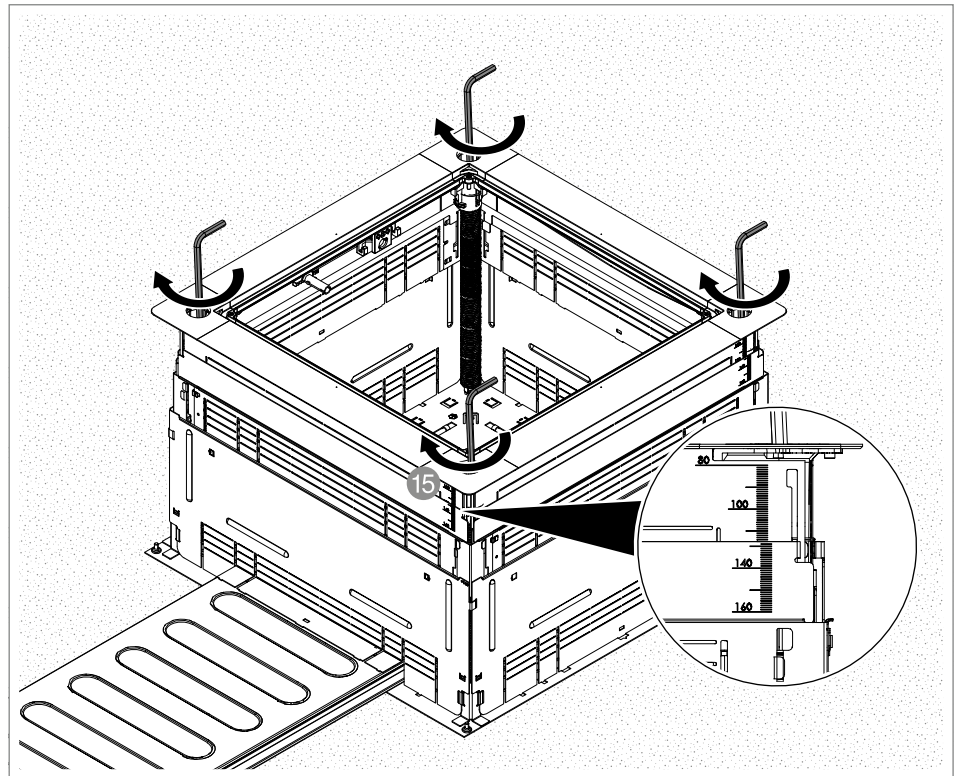

Fig. 45: Adjusting the height extension

Note! *The integrated measuring scale on the side walls of the underfloor box is suitable as an aid.*

8. Adjust the height of the cover 15 to the height of the upper edge of the screed.

Optional! *Fine adjustment is also possible with a slotted screwdriver. See page 30 Fig. 35: Fine adjustment with a slotted drive adapter.*

12 Applying the screed

ATTENTION!

Corrosion protection!

The metallic parts (underfloor duct, underfloor box and the accessories) tend towards corrosion formation when mounted in aggressive screed. When mounting the duct system in aggressive screed (e.g. magnesia screed), an epoxy-based rust protection coating must be applied to all the metallic parts.

ATTENTION!

Risk of damage!

No screed may ingress into the duct system. When the duct system is mounted in floating screed, seal off all the openings of the duct system using suitable agents.

ATTENTION!

Risk of damage!

The duct system may not have a direct connection with the poured as-

phalt!

When mounting the duct sections in poured screed, protect the duct sections with a suitable insulation material (e.g. Fasoperl plates or asphalted corrugated card).

ATTENTION!

Risk of damage through incorrect screed laying!

Incorrect mounting of the insulating edge strip can lead to an unstable position and product damage!

Apply insulating edge strips directly around the underfloor box.

Note!

Should a separating layer be required when used in floating screed/ heated screeds on insulation layers, then the box can be separated from the screed by an insulating strip (3–5 mm). For this, the separating layer must also be applied under the top socket frame.

Note!

The entire duct system must be mounted before the screed work. Otherwise, the unit cannot be created properly.

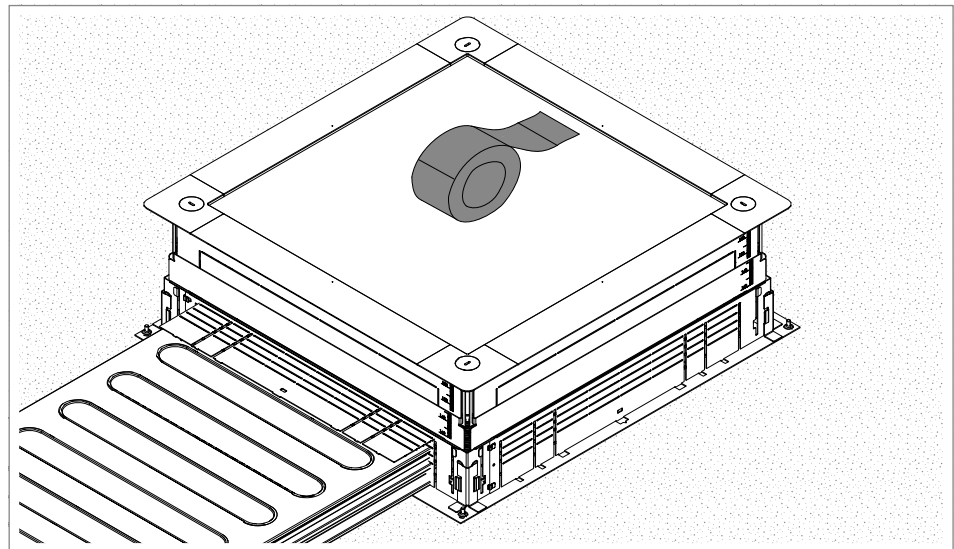

Fig. 46: Applying the insulating edge strip

1. Mask the component opening on the protective panel of the under-floor box ① with adhesive tape so that no screed can penetrate.

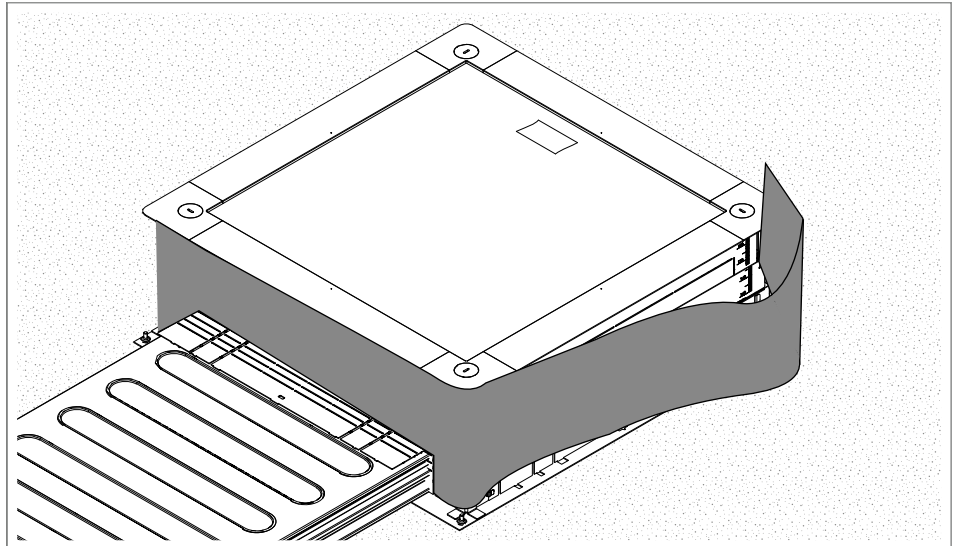

Fig. 47: Applying the insulating edge strip

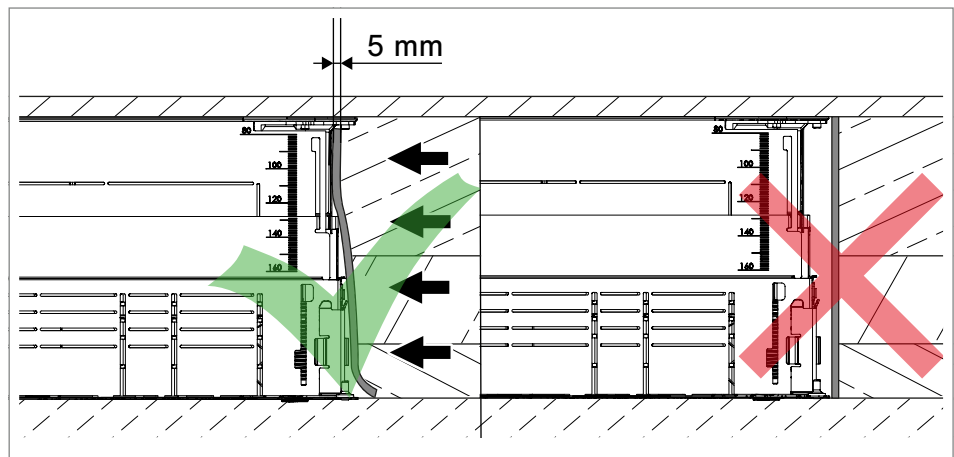

Fig. 48: Position of the insulating edge strip

Note!

The overhang at the top socket frame must be fully underlaid with screed. With cast screed and earth-moist screed, the screed must be compacted under the top socket frame. In poured screed, the compaction process, etc. may not create any cavities.

2. Apply insulating edges strips (3–5 mm) around the underfloor box ¹. In doing so, lay the insulating edge strip up to and under the upper socket edge.
3. Lay the separating layers, footfall sound insulation and heat insulation.
4. Apply the screed.

13 Completing mounting

13.1 Removing the mounting lid

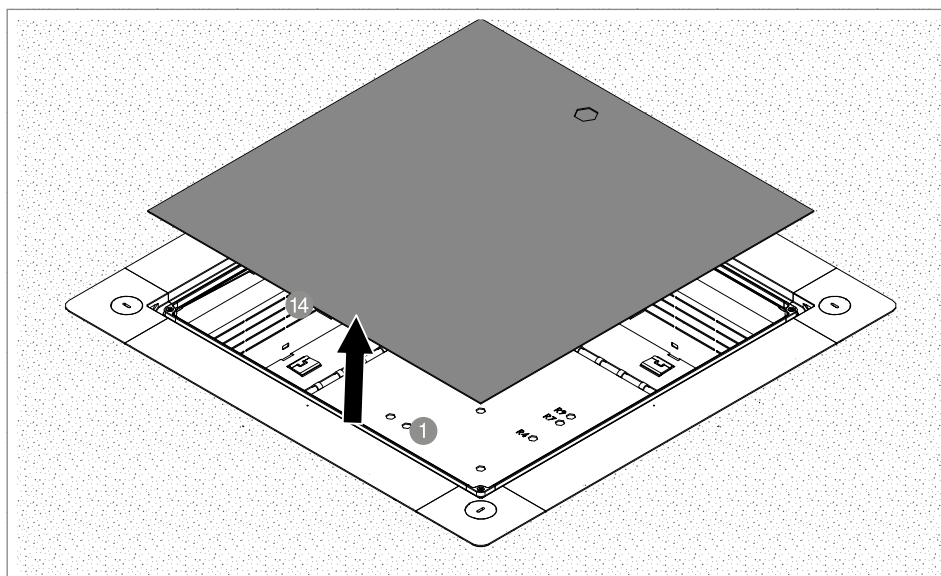

Fig. 49: Removing the mounting lid

Note! *If necessary, the hole for lifting the blanking lid can be masked during screed laying.*

Note! *The blanking lid can simply be snapped on. It is possible to remove it without releasing a screw connection.*

1. Remove the mounting protection lid 14 from the underfloor box 1.

13.2 Decoupling the underfloor box

Note! *When laying the underfloor boxes in floating screed, heated screeds or screeds on separating layers, the underfloor boxes must be decoupled. This improves noise protection and gives space to possible deformations of the screed.*

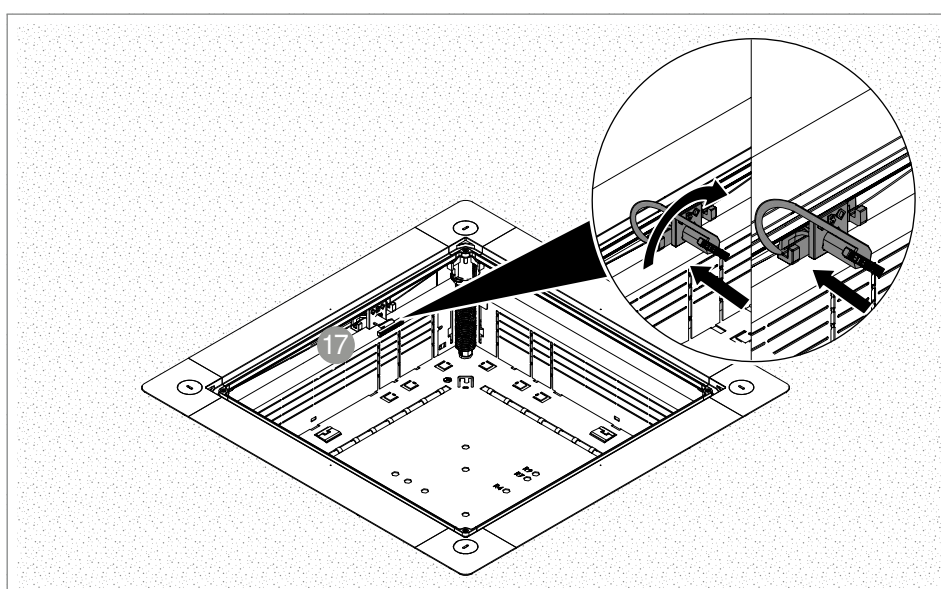

Fig. 50: Decoupling the underfloor box

1. Push in the quick height-adjustment aid 17.
2. Turn the quick height-adjustment aid 17.
3. Push the quick height-adjustment aid 17 in further.

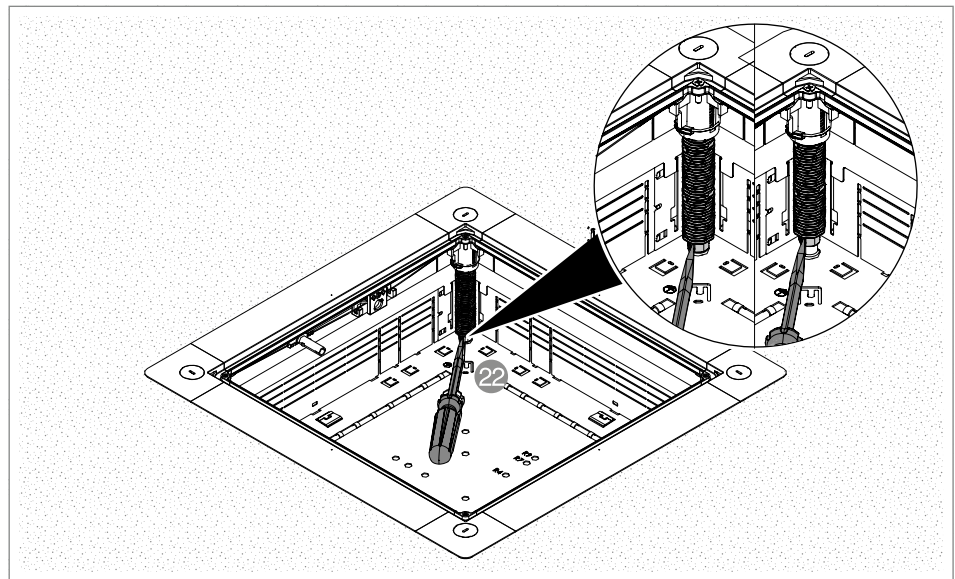

Fig. 51: Slackening the threaded rods

4. Using a slotted screwdriver, slacken the threaded rod 22.

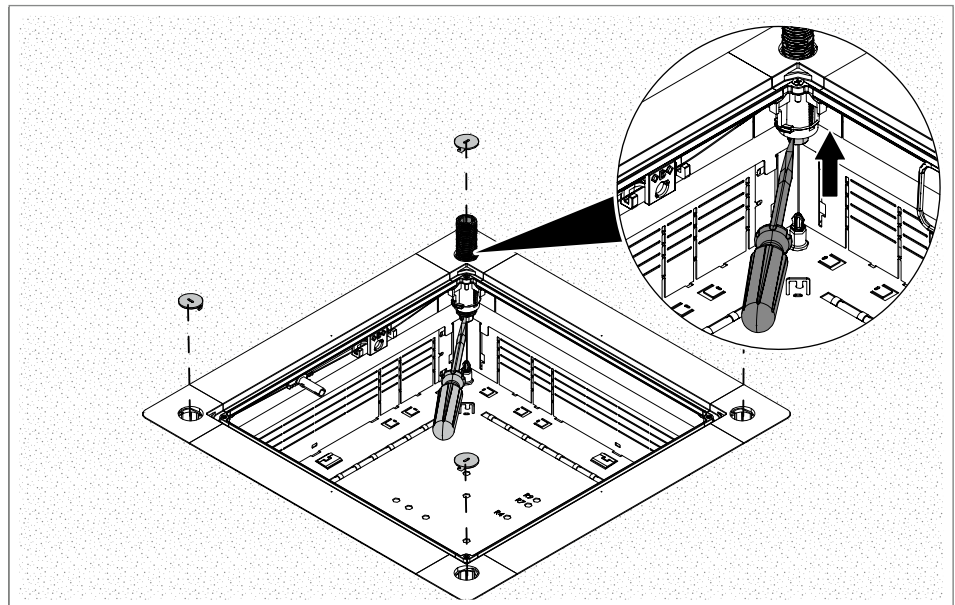

Fig. 52: Removing the threaded rods

5. Remove the cap 18.
6. Push the threaded rods 22 out.

13.3 Creating the earthing connection

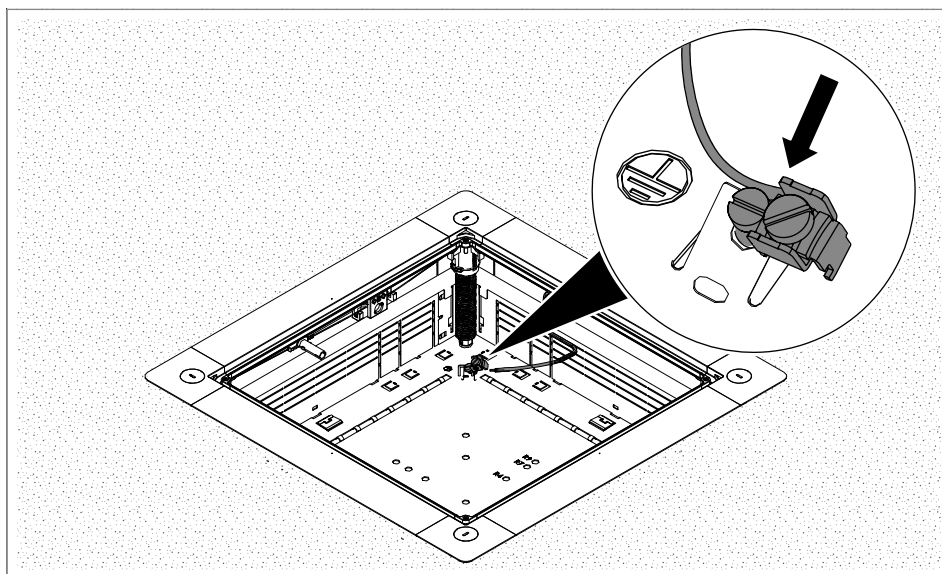

Fig. 53: Creating the earthing connection

Note!

Depending on the size of the flush-mount unit, select the fastening strap in the base so that there is contact between the earth conductor clamp and the aluminium profile.

1. Fold over the fastening strap in the base of the underfloor box.
2. Loosen the screw of the earth conductor clamp.
3. Push the protective conductor connection bracket onto the fastening strap.
4. Tighten the screw (1.2 Nm).
5. Connect the earthing cable.

13.4 Mounting the mounting lid

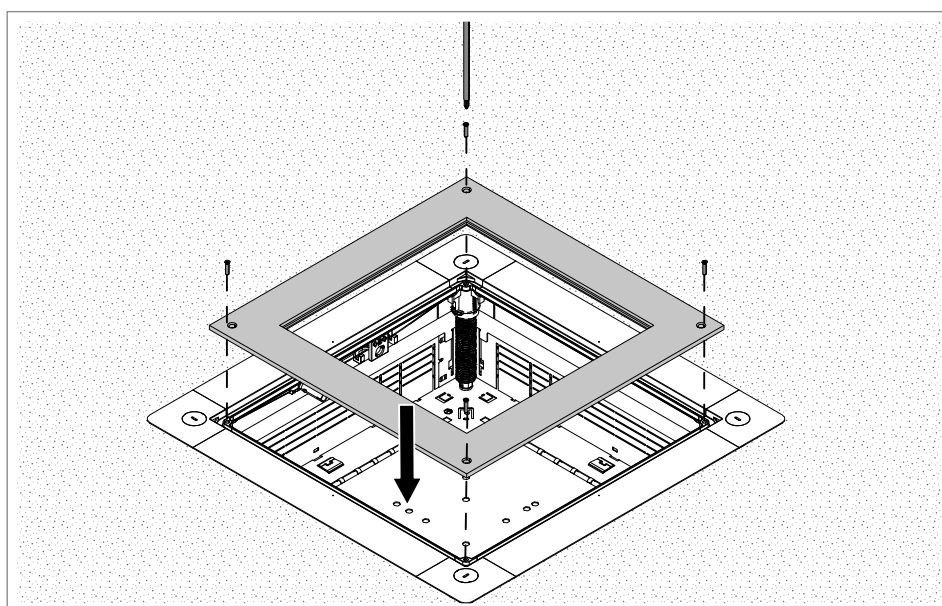

Fig. 54: Mounting the mounting lid

1. Turn out the countersunk screw 20.
2. Insert the mounting lid.
3. Turn the countersunk screw 20 in again.

14 Applying the floor covering

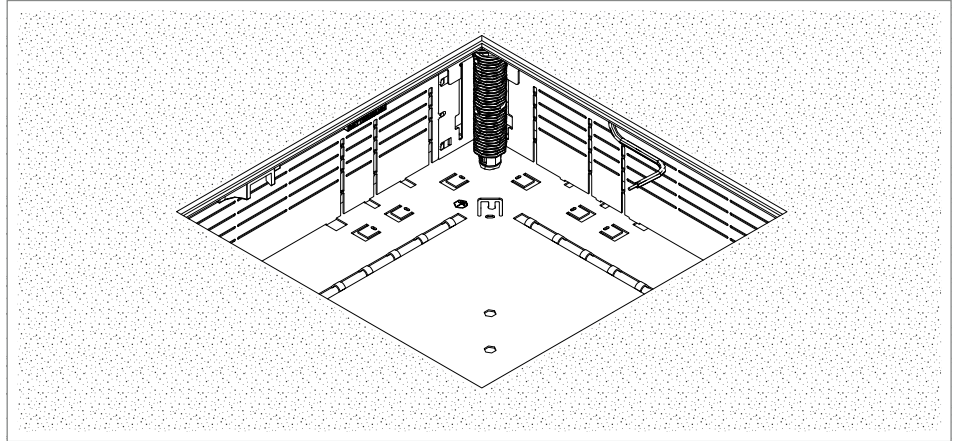

Fig. 55: Applying the floor covering

1. Apply the floor covering up to the mounting lid cut-out.

15 Mounting the service outlets/cassettes

Note! *The mounting of the service outlets/cassettes is shown with the example of a service outlet. The other service outlets/cassettes are installed in the same way.*

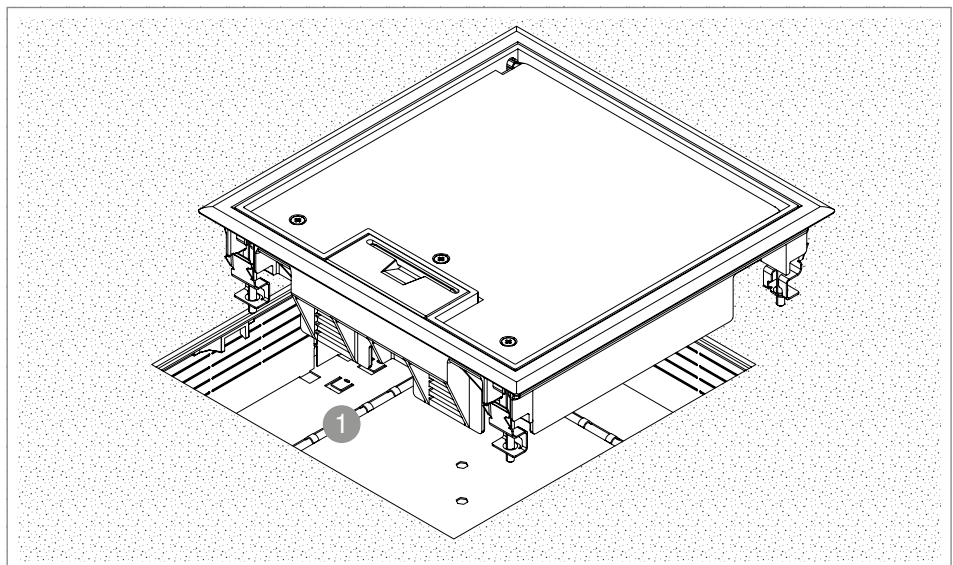

Fig. 56: Mounting the service outlets

1. Mount the service outlets in the underfloor box 1.

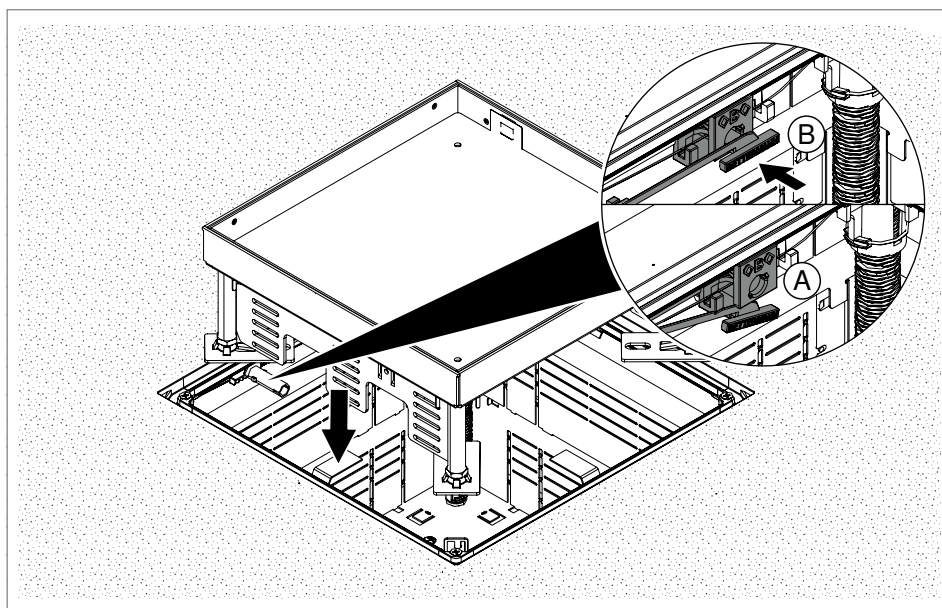

Fig. 57: Mounting a square cassette (nominal size 9)

Note!

When a square cassette (nominal size 9) is mounted into a UZD 250, there are two options:

2. a. Without decoupling: Pull the quick release aid 17 out and hook it in under the quick release aid 17.
2. b. With decoupling: Push the quick release aid 17 in up to the stop.

16 Performing the electrical installation

Note!

The electrical installation is shown using the example of a universal support.

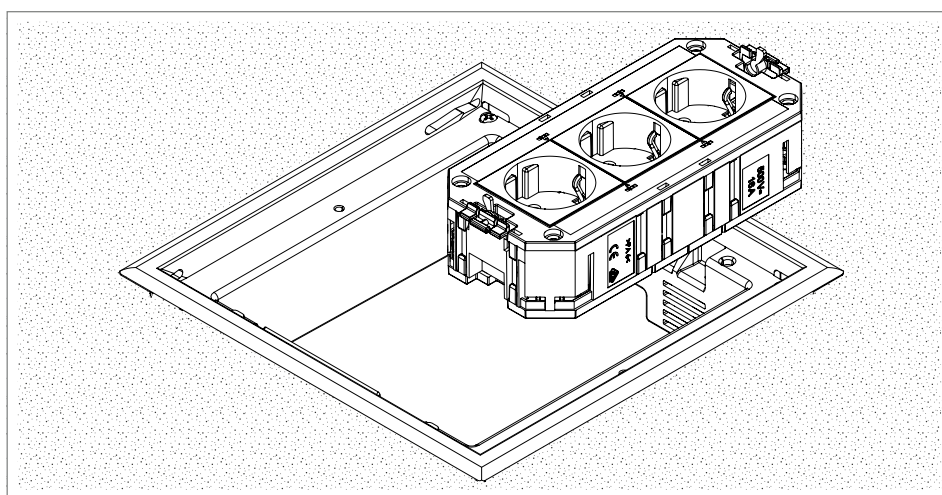

Fig. 58: Performing the electrical installation

1. Perform the electrical installation in the service outlet (according to DIN VDE 100).

17 Maintaining the duct system

ATTENTION!

Risk of damage through incorrect/insufficient care!

Insufficient care can lead to product damage!

Keep the duct system free from foreign bodies, dirt, dust and moisture.

Note!

When routing certain floor coverings, use a suitable primer in order to guarantee the connection to the socket frame (aluminium and zinc) and to avoid chemical reactions.

18 Dismantling the duct system

- Dismantle the duct system in a similar way to the mounting operation.

19 Disposing of the duct system

Comply with the local waste disposal regulations

- Packaging as household waste
- Duct system as scrap metal

20 Technical data

20.1 Underfloor boxes

Item no.	Type	Length	Width	Height	Material
7410022	UZD250-4	380 mm	400 mm	80–160 mm	Steel
7410023	UZD350-4	480 mm	500 mm	80–160 mm	Steel
7410026	UZD250-4 R	380 mm	400 mm	80–160 mm	Steel
7410025	UZD350-4 R	480 mm	500 mm	80–160 mm	Steel

Tab. 9: Technical data – underfloor boxes

20.2 Underfloor duct

Item no.	Type	Length	Width	Height	Material	Number of compartments
7400256	S2 19028-2	2,000 mm	190 mm	28 mm	Steel	2-compartment
7400258	S2 19038-2	2,000 mm	190 mm	38 mm	Steel	2-compartment
7400261	S2 19048-2	2,000 mm	190 mm	48 mm	Steel	2-compartment
7400265	S2 25028-2	2,000 mm	250 mm	28 mm	Steel	2-compartment
7400267	S2 25038-2	2,000 mm	250 mm	38 mm	Steel	2-compartment

Item no.	Type	Length	Width	Height	Material	Number of compartments
7400269	S2 25048-2	2,000 mm	250 mm	48 mm	Steel	2-compartment
7400271	S2 25058-2	2,000 mm	250 mm	58 mm	Steel	2-compartment
7400275	S3 25028-2	2,000 mm	250 mm	28 mm	Steel	3-compartment
7400279	S3 25038-2	2,000 mm	250 mm	38 mm	Steel	3-compartment
7400281	S3 25048-2	2,000 mm	250 mm	48 mm	Steel	3-compartment
7400283	S3 25058-2	2,000 mm	250 mm	58 mm	Steel	3-compartment
7400287	S3 35028-2	2,000 mm	350 mm	28 mm	Steel	3-compartment
7400289	S3 35038-2	2,000 mm	350 mm	38 mm	Steel	3-compartment
7400291	S3 35048-2	2,000 mm	350 mm	48 mm	Steel	3-compartment
7400293	S3 35058-2	2,000 mm	350 mm	58 mm	Steel	3-compartment

Tab. 10: Technical data – underfloor duct

20.3 Vertical bend

Item no.	Type	Duct width	Duct height	Material	Number of compartments
7400621	KV2 19028-2	190 mm	28 mm	Steel	2-compartment
7400623	KV2 19038-2	190 mm	38 mm	Steel	2-compartment
7400629	KV2 19048-2	190 mm	48 mm	Steel	2-compartment
7400633	KV2 25028-2	250 mm	28 mm	Steel	2-compartment
7400637	KV2 25038-2	250 mm	38 mm	Steel	2-compartment
7400641	KV2 25048-2	250 mm	48 mm	Steel	2-compartment
7400643	KV2 25058-2	250 mm	58 mm	Steel	2-compartment
7400645	KV3 25028-2	250 mm	28 mm	Steel	3-compartment
7400650	KV3 25038-2	250 mm	38 mm	Steel	3-compartment
7400653	KV3 25048-2	250 mm	48 mm	Steel	3-compartment
7400655	KV3 25058-2	250 mm	58 mm	Steel	3-compartment
7400657	KV3 35028-2	350 mm	28 mm	Steel	3-compartment
7400662	KV3 35038-2	350 mm	38 mm	Steel	3-compartment
7400665	KV3 35048-2	350 mm	48 mm	Steel	3-compartment
7400667	KV3 35058-2	350 mm	58 mm	Steel	3-compartment

Tab. 11: Technical data – vertical bend

20.4 Connection shackle

Item no.	Type	Duct width	Duct height	Material
7400988	VL 190-2	190 mm	28–48 mm	Steel
7400992	VL 250-2	250 mm	28–58 mm	Steel
7400996	VL 350-2	350 mm	28–58 mm	Steel

Tab. 12: Technical data – connection shackle

20.5 Height extension

Item no.	Type	Height-adjustment range	Material
7410134	ASH 250-4 240	160–240 mm	Steel
7410136	ASH 250-4 320	240–320 mm	Steel
7410138	ASH 350-4 240	160–240 mm	Steel
7410140	ASH 350-4 320	240–320 mm	Steel

Tab. 13: Technical data – height extension

20.6 Mounting lid (for UZD)

Item no.	Type	Length	Width	Material
7400573	DU 250-2	282 mm	282 mm	Steel
7400589	DUF 250-2	282 mm	282 mm	Steel
7400613	DUF 250-3DAT	282 mm	282 mm	Steel
7400455	DUG 250-3 2	282 mm	282 mm	Steel
7400459	DUG 250-3 4	282 mm	282 mm	Steel
7400471	DUG 250-3 R4	282 mm	282 mm	Steel
7400463	DUG 250-3 6	282 mm	282 mm	Steel
7400467	DUG 250-3 9	282 mm	282 mm	Steel
7400577	DU 350-2	383 mm	383 mm	Steel
7400597	DUF 350-2	383 mm	383 mm	Steel
7400431	DUF 350-3 DAT	383 mm	383 mm	Steel
7400505	DUG 350-3 4	383 mm	383 mm	Steel
7400517	DUG 350-3 R4	383 mm	383 mm	Steel
7400509	DUG 350-3 6	383 mm	383 mm	Steel
7400533	DUG 350-3 R7	383 mm	383 mm	Steel
7400513	DUG 350-3 9	383 mm	383 mm	Steel

Item no.	Type	Length	Width	Material
7400549	DUG 350-3 R9	383 mm	383 mm	Steel

Tab. 14: Technical data – mounting lid

OBO Bettermann
Holding GmbH & Co. KG
P. O. Box 1120
58694 Menden
GERMANY

Customer Service
Tel.: +49 2373 89 - 13 00

toi@obo.de

www.obo-bettermann.com

OBORD 220755 Date 04/2023

Building Connections

